

INTERNATIONAL

SafetyNET

Services

MANUAL
20198 EDITION

Foreword

SOLAS regulation IV/12.2 states that "Every ship, while at sea, shall maintain a radio watch for broadcasts of maritime safety information on the appropriate frequency or frequencies on which such information is broadcast for the area in which the ship is navigating".

At the request of the IMO Sub-Committee on Radiocommunications, the International SafetyNET Manual was first produced in 1994. The second edition was published in 2003 containing amendments endorsed by the Maritime Safety Committee at its seventy-sixth session in December 2002 by MSC/Circ.1064.

At its seventh meeting in September 2005, the IHO's Commission on the Promulgation of Radio Navigational Warnings (CPRNW¹) established a

¹ CPRNW was renamed the IHO WWNWS Sub-Committee (WWNWS) with

Formatert: Title_2 (Title_and_imprint_pages)

Working Group to review all World-Wide Navigational Warning Service (WWNWS) documentation. The Working Group included representation from the WMO and prepared at first, revisions to IMO resolutions A.705(17), "Promulgation of Maritime Safety Information" and A.706(17), "World-Wide Navigational Warning Service". The proposed revisions of the resolutions were circulated to IHO Member States under IHB CL 104/2007, endorsed by COMSAR at its twelfth session in April 2008 and subsequently approved by the Maritime Safety Committee at its eighty-fifth session in November/December 2008 by MSC.1/Circ.1287 and MSC.1/Circ.1288 respectively.

The IHO CPRNW Working Group then prepared the revised *Joint IMO/IHO/WMO Manual on Maritime Safety Information* incorporating the revised information from resolutions A.705(17), as amended and A.706(17), as amended. The revised text of the *Joint IMO/IHO/WMO Manual on Maritime Safety Information* was circulated to IHO Member States under cover of IHB CL 70/2008, endorsed by COMSAR at its thirteenth session in January 2009 and subsequently approved by the Maritime Safety Committee at its eighty-sixth session in May/June 2009 by MSC.1/Circ.1310.

Continuing with the holistic approach of reviewing all the MSI documents from the top-down, the IHO WWNWS-SC Working Group prepared the third revision of the International SafetyNET Manual. The revised text of the International SafetyNET Manual was circulated to IHO Member States under cover of IHB CL 68/2009, endorsed by COMSAR at its fourteenth session in March 2010 and subsequently approved by the Maritime Safety Committee at its eighty-seventh session in May 2010 by MSC.1/Circ.1364 and will come into force on 1 January 2012.

The fourth revision of the International SafetyNET Manual took place following NCSR1 in June/July 2014 and WWNWS6 in August 2014. Subsequently it was submitted to the WMO for approval prior to submission to NCSR3 for endorsement and final approval at MSC97 and publication as MSC.1/Circ.1364/Rev.1 with an in-force date of 1 January 2018.

As a result of changes to the Inmarsat satellite network and services, the fifth revision of the International SafetyNET Manual took place following NCSR 5 in February/March 2018 and WWNWS10 in August 2018.

effect from 1 January 2009.

Formatert: Uttheving

Formatert: Uttheving

Formatert: Uttheving

Formatert: Uttheving

Formatert: Uttheving

Subsequently it was submitted to the WMO for approval prior to submission to NCSR6 for endorsement and final approval at MSC 101 and publication as MSC.1/Circ.1364/Rev.2 with an in force date of 22 222X 2019.

(Add MSC date...)

1 General information

SafetyNET is an international automatic direct-printing satellite-based service for the promulgation of Maritime Safety Information (MSI), navigational and meteorological warnings, meteorological forecasts, Search and Rescue (SAR) information and other urgent safety-related messages to ships. It has been developed as a safety service of the Inmarsat C Enhanced Group Call (EGC) system to provide a simple and automated means of receiving MSI on board ships at sea. The message-selection features of SafetyNET receivers enable mariners to receive safety information broadcasts that are tailored to their particular needs.

As a part of Inmarsat's GMDSS modernization programme, SafetyNET II was developed by Inmarsat with the support from the wider maritime community in 2017. SafetyNET II, introduced innoted by NCSR 5/14/5, is an enhancement of the existing SafetyNET service, within the EGC system. For additional information on SafetyNET II, see annex xxx-6.

Provide brief info on FleetSafety...

SafetyNET fulfils an integral role in the Global Maritime Distress and Safety System (GMDSS) developed by the International Maritime Organization (IMO) and incorporated into the 1988 amendments to the International Convention for the Safety of Life at Sea (SOLAS), 1974, as amended, as a requirement for ships to which the Convention applies.

Fleet Safety is the digital satellite communications system comprising of a FleetBroadband Ship Earth System, (SES) and type approved Maritime Safety Terminal (MST) for use within the GMDSS, enabling ships to meet the majority of the satellite communications requirements of the GMDSS including Distress Alerting, reception of Maritime Safety Information (MSI), voice distress and general communications.

This Manual describes the structure and operation of the International SafetyNET – [and SafetyNET III Service[s]]. It is intended primarily for national Administrations and registered information providers, but may

Formatert: Utheving

Formatert: Skriftfarge: Rød, Utheving

Formatert: Skriftfarge: Rød

Formatert: Utheving

Formatert: Tegnskala: 100 %

Formatert: Tegnskala: 100 %

Formatert: Utheving

Formatert: Mellomrom Før: 6 pkt.

Formatert: Utheving

Formatert: Tegnskala: 100 %, Utheving

Formatert: Tegnskala: 100 %, Utheving

Formatert: Tegnskala: 100 %, Utheving

Formatert: Tegnskala: 100 %

Formatert: Tegnskala: 100 %, Utheving

Formatert: Tegnskala: 100 %

Formatert: Skriftfarge: Rød

Kommentert [ST1]: WNNWS10, Dana to check.

Formatert: Skriftfarge: Rød

Kommentert [ST2]: Move to other section. Footnote regarding GMDSS compl.

Formatert: Skriftfarge: Rød

Formatert: Høyre

Formatert: Utheving

also be useful to the mariner who requires more operational information than is found in manufacturers' equipment manuals.

2 SafetyNET service[s]

2.1 Introduction

2.1.1 SafetyNET services provides shipping with navigational and meteorological warnings, meteorological forecasts, shore-to-ship distress alerts, SAR information and other urgent information in accordance with the requirements of the International Convention for the Safety of Life at Sea (SOLAS), 1974, as amended. It is suitable for use in all sizes and types of ships. Figure 1 illustrates the way the service is structured.

2.1.2 SafetyNET and SafetyNET II are services of Inmarsat's the EGC system and are specifically designed for promulgation of MSI as a part of the GMDSS. The EGC system (technically a part of the Inmarsat-C system) provides an automatic method of broadcasting messages to both fixed and variable geographical areas. It is designed with the capability to provide services within the coverage areas of geostationary satellites, known as satellite Ocean Regions (approximately between 76°N and 76°S). In addition to providing services to ships operating in sea area A3, it also provides the means of disseminating MSI to coastal warning areas not covered by the International NAVTEX service.

Kommentert [ST3]: WWWWS10

Formatert: Uttheving

Formatert: Uttheving

Kommentert [ST4]: WWWWS10, change through document.

Formatert: Uttheving

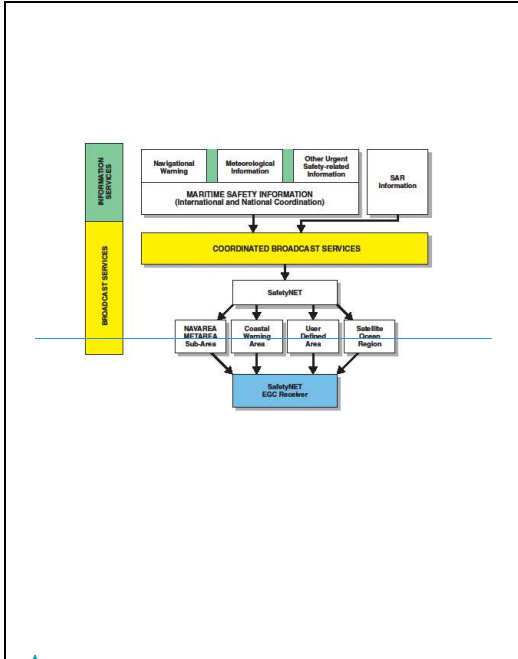

Feltkode endret

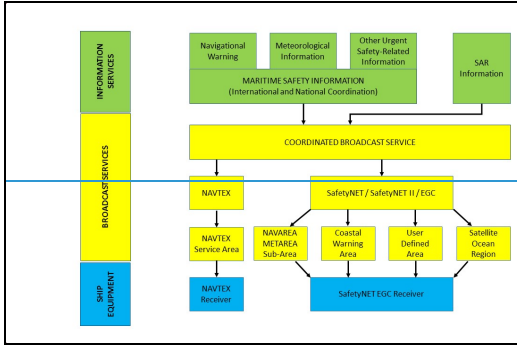

Figure 1 – The International SafetyNET Service system
 add Enhanced Group Call (EGC) and SafetyNET II to the SafetyNET
 box

Kommentert [ST5]: Blue box; delete SAFETYNET

Kommentert [ST6]: Take out EGC from SafetyNet... box.
 SafetyNet Services

Kommentert [JD7]: New Diagram added to include SafetyNET II and EGC

Formatert: Utheving

Formatert: Utheving

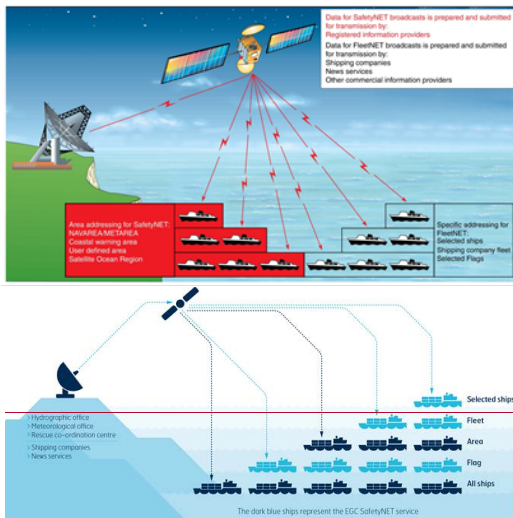

Figure 2 – Basic concept of the Inmarsat Enhanced Group Call system. Inmarsat will provide new figure.

Formatert: Utheving

Formatert: Utheving

Formatert: Utheving

2.1.3 **SafetyNET [and SafetyNET II]** offers the ability to direct a message to a given geographical area. The area may be fixed, as in the case of a NAVAREA/METAREA or coastal warning area; or it may be a **usef defined user-defined** area (circular or rectangular). A user defined area is used for messages, such as a local storm warning or a shore-to-ship distress alert, for which it is inappropriate to alert ships in an entire satellite **o**cean **R**egion or NAVAREA/METAREA. The general EGC system capabilities are shown in **F**igure 2.

2.1.4 SafetyNET messages are submitted by registered information providers for broadcast to the appropriate satellite **o**cean **R**egion(s)

via an Inmarsat C Land Earth Station (LES).

2.1.5 SafetyNET II messages are submitted by registered information providers via a secure interface to the Inmarsat network. See aAnnex xxx6 for more information.

2.1.6 Messages are broadcast according to their priority, i.e. distress, urgency or safety. Aboard ship, messages are received by type-approved Inmarsat EGC C or mini-C mobile terminals, with EGC SafetyNET capability.

Kommentert [ST8]: Removed "web", WWWWS10

Formatert: Uttheving

Formatert: Uttheving

Formatert: Uttheving

2.2 Definitions

2.2.1 For the purposes of this manual, the following definitions apply:

- .1 *Coastal warning* means a navigational warning or in-force bulletin promulgated as part of a numbered series by a National Coordinator. Broadcast should be made by the International NAVTEX service to defined NAVTEX service areas and/or by the International SafetyNET service to coastal warning areas. In addition, Administrations may issue coastal warnings by other means.
- .2 *Coastal warning area* means a unique and precisely defined sea area within a NAVAREA/METAREA or Sub-area established by a coastal state for the purpose of coordinating the broadcast of coastal maritime safety information through the SafetyNET service.
- .3 *Enhanced Group Call (EGC)* means the system for broadcasting messages via the mobile satellite communications system operated by Inmarsat Global Limited. EGC is a part of the Inmarsat C system and supports two services: SafetyNET and FleetNET.
- .4 *FleetNET* means the commercial service for the broadcasting

Formatert: in1 (Body_text), Innrykk: Venstre: 0 cm

and automatic reception of fleet management and general public information by means of direct printing through Inmarsat's EGC system. Some receivers for FleetNET may not be able to receive SafetyNET.

5.

Fleet Safety means the digital satellite communications system comprising of a FleetBroadband SES and type approved Maritime Safety Terminal for use within the GMDSS, enabling ships to meet the majority of the satellite communications requirements of the GMDSS including distress alerting, reception of maritime safety information, voice distress and general communications.

Formatert: Utheving

Formatert: in1 (Body_text), Innrykk: Venstre: 0 cm

Kommentert [JD9]: Definition for Fleet Safety

Kommentert [ST10]: D

Kommentert [ST11R10]: Dana review

Kommentert [ST12]: WWWS10, IMO review.

.65 *Global Maritime Distress and Safety System (GMDSS)* means the global communications service based upon automated systems, both satellite and terrestrial, to provide distress alerting and promulgation of maritime safety information for mariners.

.67 *HF NBDP* means High Frequency narrow-band direct-printing, using radio—telegraphy as defined in Recommendation ITU-R M.688, as amended.

.87 *In-force bulletin* means a list of serial numbers of those NAVAREA, Sub-area or coastal warnings in force issued and broadcast by the NAVAREA Coordinator, Sub-area Coordinator or National Coordinator.

.98 *Inmarsat C* means the digital satellite communications system for store-and-forward text or data messaging using mobile terminals with omni-directional antennas. Inmarsat C ~~is the only system that~~ allows ships to meet the majority of the satellite communication requirements of the GMDSS including distress alerting, reception of maritime safety information and general communications.

Kommentert [JD13]: This should be removed as Fleet Safety will be included

.109 *Inmarsat Mini-C* means smaller terminals, based on the same technical requirements as Inmarsat C terminals. Some

models are approved as GMDSS compliant terminals.

- .110 *Inmarsat Fleet* means the digital satellite communication system that provides voice and flexible data communication services, e-mail and secure internet access for maritime users, comprising a family of Fleet F77, F55 and F33 mobile terminals. The Inmarsat Fleet F77 system provides voice distress and safety functionality and meets the requirements of resolution A.1001(25).
- .142 *Inmarsat FleetBroadband* means the communication service that provides voice and high-speed data services, simultaneously, through compact terminals for maritime users.
- .132 *International NAVTEX service* means the coordinated broadcast and automatic reception on 518 kHz of maritime safety information by means of narrow-band direct-printing telegraphy using the English language.²
- .143 *International SafetyNET service* means the coordinated broadcast and automatic reception of maritime safety information via the Inmarsat Enhanced Group Call (EGC) system, using the English language, in accordance with the provisions of the International Convention for the Safety of Life at Sea, 1974, as amended.
- .154 *International SafetyNET II service* means Inmarsat's enhancement to the SafetyNET service, providing co-ordinated broadcasting and automated reception of maritime safety information on Inmarsat approved terminals including Inmarsat C, Mini C and Fleet Safety, via an interactive web-based interface, using the English language, in accordance with the provisions of the International Convention for the Safety of Life at Sea, 1974, as amended.
- .16 *Issuing Service* means a National Meteorological Service which has accepted responsibility for ensuring that meteorological warnings and forecasts for shipping are disseminated through the Inmarsat SafetyNET service to the METAREA for which the Service has accepted responsibility under the broadcast requirements of the GMDSS WWWIWS.

Kommentert [DJ14]: Repeated in 41 +42

Formatert: Skrift: Kursiv, Utheving

Formatert: Skrift: Kursiv

Kommentert [ST15]: WWWWS10, reword?

Kommentert [ST16]: WWWWS10

² As set out in the IMO NAVTEX Manual.

.175 *Land Earth Station (LES)* means a fixed terrestrial station acting as a gateway between terrestrial communication networks and the Inmarsat satellites in the maritime mobile-satellite service. This may also be referred to as a Coast Earth Station (CES).

.186 *Land Earth Station Operator (LESO)* means an Inmarsat service provider which owns and operates the LES.

.197 *Local warning* means a navigational ~~warning~~ warning, which covers inshore waters, often within the limits of jurisdiction of a harbour or port authority.

.2018 *Maritime safety information (MSI)*³ means navigational and meteorological warnings, meteorological forecasts and other urgent safety-related messages broadcast to ships.

.2149 *Maritime safety information service* means the internationally and nationally coordinated network of broadcasts containing ~~information which~~ information, which is necessary for safe navigation.

.220 *METAREA* means a geographical sea area⁴ established ~~for the purpose of~~ for coordinating the broadcast of marine meteorological information. The term METAREA followed by a roman numeral may be used to identify a particular sea area. The delimitation of such areas is not related to and shall not prejudice the delimitation of any boundaries between States (see ~~f~~Figure 3).

.234 *METAREA Coordinator* means the authority charged with ~~coordinating~~ coordinating marine meteorological information broadcasts by one or more National Meteorological Services acting as Preparation or Issuing Services within the METAREA.

.224 *Meteorological information* means the marine meteorological

Formatert: in1 (Body_text:Body_text_less_space), Innrykk: Venstre: 0 cm, Første linje: 0 cm, Tabulatorstopp: Ikke på 1,75 cm

Formatert: Innrykk: Hengende: 0,85 cm

Formatert: in1 (Body_text:Body_text_less_space), Innrykk: Venstre: 0 cm, Første linje: 0 cm, Tabulatorstopp: Ikke på 1,75 cm

Formatert: Innrykk: Hengende: 0,85 cm

³ As defined in Regulation IV/2 of the 1974 SOLAS Convention, as amended.

⁴ Which may include inland seas, lakes and waterways navigable by sea-going ships.

warnings and forecast information in accordance with the provisions of the International Convention for the Safety of Life at Sea, 1974, as amended.

.253 *Mobile Earth Station (MES)* means a mobile user terminal in the Inmarsat maritime mobile-satellite service. This may also be referred to as Ship Earth Station (SES).

.26 — Maritime Safety Terminal (MST) means an Inmarsat type approved safety terminal for use within the Fleet Safety system.

.247 *National Coordinator* means the national authority charged with collating and issuing coastal warnings within a national area of responsibility.

.285 *National NAVTEX service* means the broadcast and automatic reception of maritime safety information by means of narrow-band direct-printing telegraphy using frequencies other than 518 kHz and languages as decided by the Administration concerned.

.296 *National SafetyNET service* means the broadcast and automatic reception of maritime safety information via the Inmarsat EGC system, using languages as decided by the Administration concerned.

.3027 *NAVAREA* means a geographical sea area* established for the purpose of coordinating the broadcast of navigational warnings. The term NAVAREA followed by a roman numeral may be used to identify a particular sea area. The delimitation of such areas is not related to and shall not prejudice the delimitation of any boundaries between States (see Figure 4).

*which may include inland seas, lakes and waterways navigable by sea-going ships.

.3128 *NAVAREA Coordinator* means the authority charged with coordinating, collating and issuing NAVAREA warnings for a designated NAVAREA.

.3229 *NAVAREA warning* means a navigational warning or in-force bulletin promulgated as part of a numbered series by a NAVAREA Coordinator.

.303 *Navigational warning* means a message containing urgent

Formatert: Utheving

Kommentert [ST17]: WWNWS10, Remove.

information relevant to safe navigation broadcast to ships in accordance with the provisions of the International Convention for the Safety of Life at Sea, 1974, as amended.

- .341 *NAVTEX* means the system for the broadcast and automatic reception of maritime safety information by means of narrow-band direct-printing telegraphy.
- .352 *NAVTEX Coordinator* means the authority charged with operating and managing one or more NAVTEX stations broadcasting maritime safety information as part of the International NAVTEX service.
- .363 *NAVTEX service area* means a unique and precisely defined sea area for which maritime safety information is provided from a particular NAVTEX transmitter.
- .374 *Network Coordination Station (NCS)* means a fixed land station in the Inmarsat satellite communications ~~system~~ which system, which controls channel assignments and provides the network management functions for each of the four satellite Ocean Regions. NCSs also transmit EGC messages on the NCS common channel.
- .385 *Other urgent safety-related information* means maritime safety information broadcast to ships that is not defined as a navigational warning or meteorological information. This may include, but is not limited to, significant malfunctions or changes to maritime communications systems, and new or amended mandatory ship reporting systems or maritime regulations affecting ships at sea.
- .396 *Registered information provider* means a Maritime Safety Information Provider (MSI provider), authorized in accordance with Annex 2 of the International SafetyNET Services Manual, which has an agreement with one or more LES(s) for providing SafetyNET and SafetyNET II services.
- .3740 *Rescue Coordination Centre (RCC)* means a unit responsible for promoting efficient organization of Search and Rescue services and for coordinating the conduct of Search and Rescue operations within a search and rescue region. Note: the term RCC will be used within this Manual to apply to either joint, aeronautical or maritime centres; JRCC, ARCC

or MRCC will be used as the context warrants.

.4138 SafetyNET means the international service for the broadcast and automatic reception of maritime safety information via the Inmarsat EGC system. SafetyNET receiving capability is part of the mandatory equipment which is required to be carried by certain ships in accordance with the provisions of the International Convention for the Safety of Life at Sea, 1974, as amended.

.4239 SafetyNET II means the enhanced SafetyNET service. SafetyNET II provides an interactive web portal or application programming interface (API) for information providers to create their MSI messages and deliver them over the Inmarsat EGC system.

SafetyNET II means Inmarsat's enhancement to the SafetyNET service, providing co-ordinated broadcasting and automated reception of maritime safety information on Inmarsat approved terminals including Inmarsat C, Mini C and Fleet Safety, via an interactive web-based interface, using the English language, in accordance with the provisions of the International Convention for the Safety of Life at Sea, 1974, as amended.

.43 Search and ARescue (SAR) information means distress alert relays and other urgent Ssearch and Rrescue information broadcast to ships.

.404 Satellite Ocean Region means the area on the earth's surface within which a mobile or fixed antenna can obtain line-of-sight communications with one of the four-five primary Inmarsat C-geostationary satellites. This area may also be referred to as the "footprint".

- Kommentert [JD18]:** Need a definition for SNII
- Kommentert [ST19]:** WWNWS10, Review, definition in light of the term SafetyNet services.
- Formatert:** Innrykk: Venstre: 0 cm, Første linje: 0 cm
- Formatert:** Skrift: Kursiv
- Kommentert [ST20]:** WWNWS10.
- Formatert:** Skrift: Ikke Kursiv
- Formatert:** Skrift: Ikke Kursiv
- Formatert:** Utheving
- Formatert:** Skrift: 9,5 pkt, Utheving
- Formatert:** Skrift: 9,5 pkt, Utheving
- Formatert:** Skrift: 9,5 pkt, Skriftfarge: Rød, Utheving
- Formatert:** Skrift: 9,5 pkt, Utheving
- Formatert:** Skrift: 9,5 pkt, Utheving
- Kommentert [ST21]:** WWNWS10, Modify.
- Kommentert [ST22]:** WWNWS10, Add note to annex.
- Kommentert [ST23]:** Insert to 705
- Formatert:** in1 (Body_text)
- Formatert:** Skrift: (Standard) Optima LT Std, 9,5 pkt, Ikke
- Formatert tabell**
- Formatert:** Skrift: (Standard) Optima LT Std, 9,5 pkt, Ikke
- Formatert:** Blokkjustert
- Formatert:** Skrift: (Standard) Optima LT Std, 9,5 pkt, Ikke
- Formatert:** Blokkjustert
- Formatert:** Skrift: (Standard) Optima LT Std, 9,5 pkt, Ikke
- Formatert:** Blokkjustert

Ocean Region	Satellite	Terminals
<u>AOR-E (Atlantic Ocean Region East)</u>	<u>AOR-E</u>	<u>Inmarsat C & Mini C</u>
<u>AOR-W (Atlantic Ocean Region West)</u>	<u>AMER</u>	<u>Inmarsat C, Mini C & Fleet Safety</u>
<u>POR (Pacific Ocean Region)</u>	<u>APAC</u>	<u>Inmarsat C, Mini C & Fleet Safety</u>

IOR (Indian Ocean Region)	EMEA	Inmarsat C, Mini C
MEAS (Middle East and Asia)	MEAS	&Fleet Safety
		Fleet Safety

Formatert: Skrift: (Standard) Optima LT Std, 9,5 pkt, Ikke

Formatert: Blokkjustert

Formatert: Skrift: (Standard) Optima LT Std, 9,5 pkt, Ikke

Formatert: Blokkjustert

~~Atlantic Ocean Region – East (AOR-E)~~

~~Atlantic Ocean Region – West (AOR-W)~~

~~Indian Ocean Region (IOR)~~

~~Pacific Ocean Region (POR)~~

- .415 *Sea Area A1* means an area within the radiotelephone⁵ coverage of at least one VHF coast station in which continuous DSC⁵ alerting is available, as may be defined by a Contracting Government.
- .462 *Sea Area A2* means an area, excluding sea area A1, within the radiotelephone coverage of at least one MF coast station in which continuous DSC alerting is available, as may be defined by a Contracting Government.
- .473 *Sea Area A3* means an area, excluding sea areas A1 and A2, within the coverage of an **Inmarsat geostationary satellite** in which continuous alerting is available.
- .484 ***Sea Area A4* means an area outside sea areas A1, A2 and A3.**
- .459 *Sub-area* means a subdivision of a NAVAREA/METAREA in which a number of countries have established a coordinated system for the promulgation of maritime safety information. The delimitation of such areas is not related to and shall not prejudice the delimitation of any boundaries between States.
- .5046 *Sub-area Coordinator* means the authority charged with coordinating, collating and issuing Sub-area warnings for a designated Sub-area.
- .5147 *Sub-area warning* means a navigational warning or in-force

Formatert: Text_in2 (Body_text), Innrykk: Venstre: 1,69 cm

Formatert: Ikke Utheving

Formatert: Utheving

Formatert: Utheving

⁵ Digital selective calling (DSC) means a technique using digital codes which enables a radio station to establish contact with and transfer information to another station or group of stations and complying with the relevant recommendations of the International Radio Consultative Committee (CCIR) – "Radiocommunications Bureau of the International Telecommunication Union (ITU)" from 1 March 1993.

bulletin promulgated as part of a numbered series by a Sub-area coordinator. Broadcast should be made by the International NAVTEX service to defined NAVTEX service areas or by the International SafetyNET and SafetyNET II service (through the appropriate NAVAREA Coordinator).

.5148 *User defined area* means a temporary geographic area, either circular or rectangular, to which maritime safety information is addressed.

.5249 *UTC* means Coordinated Universal ~~Time~~ Time, which is equivalent to GMT (or ZULU) as the international time standard.

.503 *World-Wide Met-ocean Information and Warning Service (WMMIWS)*⁶ means the internationally coordinated service for the promulgation of meteorological warnings and forecasts.

.544 *World-Wide Navigational Warning Service (WWNWS)*⁷ means the internationally and nationally coordinated service for the promulgation of navigational warnings.

.525 In the operating procedures *coordination* means that the allocation of the time for data broadcast is central~~ized~~ized, the format and criteria of data transmissions are compliant as described in the *Joint IMO/IHO/WMO Manual on Maritime Safety Information* and that all services are managed as set out in resolutions A.705(17), as amended, A.706(17), as amended, and A.1051(27), as amended.

⁶ As set out in resolution A.1051(27), as amended

⁷ See resolution A.706(17), as amended.

2.2.2 METAREA Limits

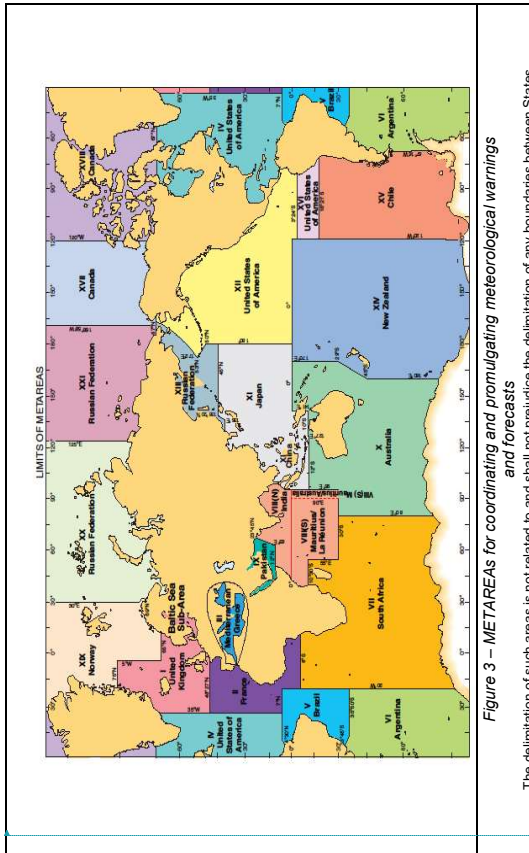

Figure 3 – METAREAs for coordinating and promulgating meteorological warnings and forecasts

The delimitation of such areas is not related to, and shall not prejudice the delimitation of any boundaries between States.

Kommentert [DJ24]: Might change – stage 4 migration

Feltkode endret

2.2.3 NAVAREAs with Inmarsat satellite Ocean

Region coverage

Kommentert [DJ25]: Can have separate maps

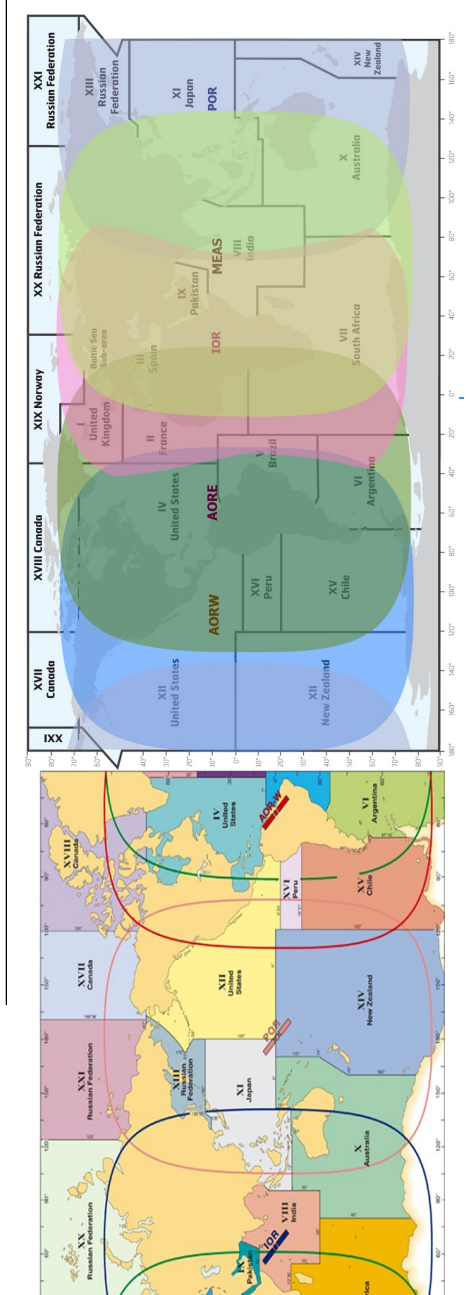

mutgating navigational warnings under including Inmarsat satellite footprints
 -see the delimitation of any boundaries between States

3 General features of the Inmarsat EGC system

3.1 The Inmarsat C-EGC system supports SafetyNET and SafetyNET III – for promulgation of MSI, two different services:

~~.1 – SafetyNET – for promulgation of MSI; and~~

~~.2 – FleetNET – for transmission of fleet management, general public information and other information to fleets or groups of ships. The FleetNET service is not part of the GMDSS.~~

3.2 All navigable waters of the world between 76°N and 76°S are covered by satellites in the Inmarsat system. Each satellite transmits EGC messages on a designated channel; this channel is optimized to enable the signal to be received by type approved Inmarsat C or mini-C EGC terminals with EGC SafetyNET capability. Reception of EGC messages is normally not affected by the position of the ship within the satellite Ocean Region, atmospheric conditions or time of day.

3.3 SafetyNET and ~~SafetyNET~~ SafetyNET III messages are addressed to a geographical area (area calls), ~~whereas FleetNET messages are addressed to groups of ships (group calls):~~

~~These .1 – a~~ Area calls (SafetyNET) can be addressed to a fixed geographical area (NAVAREA/METAREA or coastal warning area) or to a user defined area selected by an MSI provider. Area calls will be received automatically by any SafetyNET-Inmarsat EGC receiver within the area. To receive SafetyNET-EGC coastal warnings, the Inmarsat EGC receiver must be set up with appropriate B₁ and B₂ codes – where the B₁ code is the designator of the defined area and the B₂ code is the subject indicator (see section 13.4).

~~.2 – Group calls (FleetNET) will be received automatically by any ship whose EGC receiver acknowledges the unique group identity associated with a particular message.~~

Formatert: Utheving

Formatert: n (Body_text)

Formatert: Utheving

Formatert: Innrykk: Venstre: 0,85 cm, Første linje: 0 cm

Formatert: Skrift: Ikke Kursiv

4 Planning of new ~~Registering for~~ SafetyNET services

4.1 Authorities wishing to become officially registered information providers of MSI to ships at sea via SafetyNET ~~services~~ ~~services~~ should contact the IMO via the International SafetyNET ~~Enhanced Group Call~~ Coordinating Panel at an early stage for advice. The plans of any prospective registered information providers should be coordinated with the IMO, IHO and WMO and with other national authorities, before authorization to broadcast via SafetyNET ~~services~~ may be granted by the ~~International SafetyNET Coordinating Panel~~, in accordance with the procedures set out in Annex 2.

Formatert: Utveiving

Formatert: Utveiving

4.2 Once authorized and registered, ~~information providers~~ ~~MSIP's~~ should contact the LES operator(s) or ~~Inmarsat service provider(s)~~ ~~as~~ they desire to use for promulgation of information to their areas of responsibility, in order to determine specific details for addressing messages, accessing the LES, charges and payment for services and any other matters with respect to providing MSI to mariners.

4.3 ~~The International SafetyNET Coordinating Panel~~, in cooperation with IHO and WMO, undertakes the coordination of times for scheduled transmissions.

Formatert: Utveiving

4.4 Mariners should be informed of the establishment of a SafetyNET service by the inclusion of full details in Notices to Mariners and other national nautical publications and the IMO Master Plan of Shore-Based Facilities for the GMDSS ~~as amended~~. In addition, full details of the service should be sent to the ~~International SafetyNET Coordinating Panel~~ at the address given in Annex 1.

Formatert: Utveiving

4.5 Questions concerning promulgation of MSI through the ~~EGG~~ SafetyNET ~~services~~ can be addressed to the ~~International SafetyNET Coordinating Panel~~ at the address given in Annex 1.

Formatert: Utveiving

4.6 Questions concerning the operation of the Inmarsat system should be addressed to

Maritime Safety Services,

Inmarsat Global Ltd.,

99 City Road,

London EC1Y 1AX,

United Kingdom,

E-mail address: maritime.safety@inmarsat.com.

5 Changes to existing SafetyNET services

5.1 Registered information providers MSIPs wishing to change their existing SafetyNET service should follow the same coordination procedures as for a new service, in accordance with the procedures set out in Annex 2.

Kommentert [ST26]: WWWWS10, remove MSIP in doc.

5.2 Mariners should be informed of the changes to an existing SafetyNET service by the inclusion of full details in Notices to Mariners and other national nautical publications and the IMO Master Plan of Shore-Based Facilities for the GMDSS, as amended. In addition, full details of the service should be sent to the International SafetyNET Coordinating Panel at the address given in Annex 1.

Kommentert [ST27]: WWWWS10, check doc.

Formatert: Uttheving

6 Operation of the International SafetyNET Services

Formatert: Uttheving

6.1 Given the size of a satellite Ocean Region, some form of selectivity in receiving and printing the various messages is required. All ships within the footprint of a selected satellite will receive area calls, however, they will only be displayed and printed by those receivers that recognize both:

- .1 the fixed geographical area (NAVAREA/METAREA), user defined area as appropriate; and
- .2 for coastal warnings, the coastal warning area and the

subject indicator for the message.

6.2 The message format includes a preamble which preamble, which enables the EGC receiver to display and print only those MSI messages which messages, which relate to its present position, to the intended route, or to the aforementioned areas as programmed by the operator.

6.3 For coastal warning areas messages, the MSI provider must ensure that the preamble includes the B₁ code identifier allocated for the particular area, along with the appropriate B₂ code subject indicator (see section 13.4). The EGC receiver can be set to reject messages concerning certain optional subjects which subjects, which may not be required by the ship (e.g. LORAN messages may be rejected in a ship which ship, which is not fitted with a LORAN receiver). Receivers also use the B₂ code subject indicator to identify coastal warnings which warnings, which, because of their importance, may NOT be rejected.

6.4 Reception of certain types of messages, such as shore-to-ship distress alerts, SAR information, meteorological warnings and forecasts and navigational warnings, addressed to a geographical area within which the EGC receiver is located, is mandatory and cannot be suppressed by ships in the affected area. These messages are identified by the C₂ service codes: 00, 04, 14, 24, 31, 34 and 44 (see Annex 4).

Kommentert [ST28]: WNNWS10, Check doc.

6.5 When a message has been received error-free, a record is made of the message identification (the unique sequence number, the LES unique identifier and the service code) associated with that message. The unique sequence number is used to suppress the printing of repeated transmissions of the same message.

6.6 An EGC receiver is capable of storing at least 255 message identifications. These message identifications are stored with an indication of the number of hours that have elapsed since the last receipt of the message. Subsequent reception of the same message identification will reset this timer. After between 60 and 72 hours, message identifications may be automatically erased. If the number of received message identifications exceeds the capacity of memory allocated, the oldest message identification will be erased.

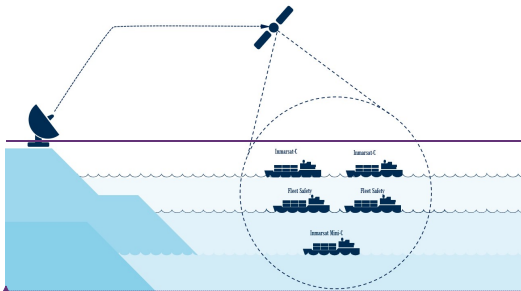
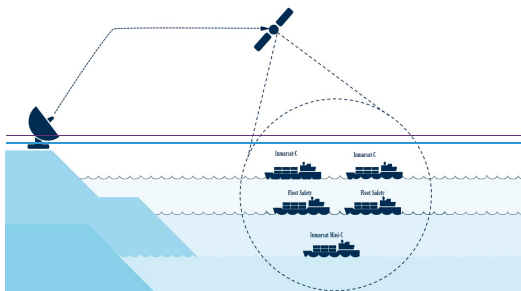

Figure 5 – SafetyNET / SafetyNET II service messages addressed to a circular area



Formatert: Kontroller staving og grammatikk

Kommentert [ST29]: WWNWS10, Check doc.

Formatert: Skrift: Kursiv

Formatert: Skrift: Kursiv, Utheving

Formatert: Skrift: Kursiv

Formatert: Image (Body_text)

Formatert: Skrift: Kursiv

Formatert: Skrift: Kursiv

Formatert: Skrift: Kursiv

Formatert: Kontroller staving og grammatikk

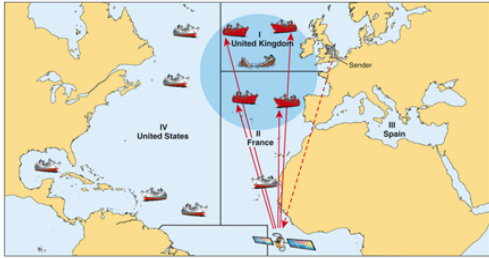

Figure 5 – SafetyNET message addressing to a circular area

~~Figure 5 – SafetyNET / SafetyNET II message addressing to a circular area~~

~~Inmarsat to provide new figure...~~

Formatert: Ikke Utheving

Formatert: Venstre

Formatert: Utheving



Figure 6 – SafetyNET message addressing to a rectangular area

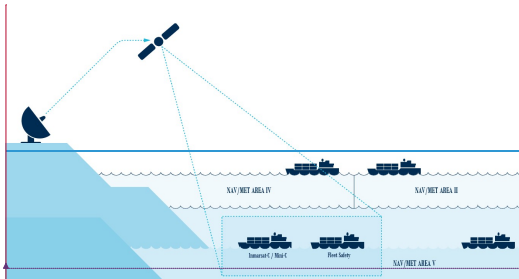

Figure 6 – SafetyNET / SafetyNET II service message addressing to a rectangular area

Kommentert [ST30]: WWNWS10, Dana to change.

Formatert: Kontroller staving og grammatikk

Formatert: Kontroller staving og grammatikk

Formatert: Skrift: Kursiv, Kontroller staving og grammatikk

Formatert: Skrift: Kursiv, Ikke Utheving

Formatert: Skrift: Kursiv, Ikke Utheving

Formatert: Image (Body_text)

Formatert: Skrift: Kursiv, Ikke Utheving

Formatert: Skrift: Kursiv

Formatert: Skrift: Kursiv

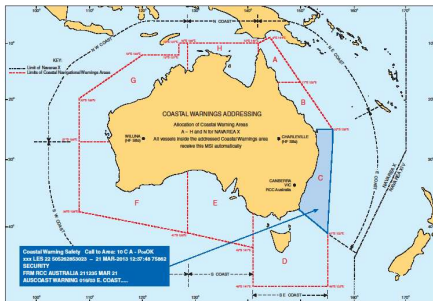

Figure 7 – SafetyNET *services message*-addressing to a coastal warning area

inmarsat to provide new figures...

6.7 **SafetyNET – SafetyNET and SafetyNET SafetyNET II service** messages can be addressed to user-defined areas, which may be circular or rectangular in shape (see Figures 5 and 6). A circular area is described by latitude and longitude of the centre in degrees and radius of the circle in nautical miles. A rectangular area is described by latitude and longitude of the south-west corner in degrees and extension in degrees to the north and east of the rectangle. Messages may also be address to a coastal warning area (see Figure 7).

6.8 In the case of a ship in distress, it is normal to create a circular user defined area (C₂ service code 14), defined by the position of the casualty and a radius around the casualty to alert ships that may be able to render assistance (see Figure 5). If no response is received from any ship at the first call, the area can be expanded in steps until an acknowledgement by one or more ships is received. In cases where the position of the distress is unknown, a shore-to-ship distress alert can be transmitted to all ships (C₂ service code 00), in a given satellite ocean

Feltkode endret

Formatert: Venstre, Tabulatorstopp: 7,2 cm, Left + Ikke på 1,69 cm + 2,12 cm + 2,54 cm + 2,96 cm + 3,39 cm + 3,81 cm + 4,23 cm

Formatert: Uttheving

Region. SAR coordination messages shall only be addressed to circular (C₂ service code 14) or to rectangular (C₂ service code 34) user defined areas (see figure 6).

7 Promulgation of Maritime Safety Information (MSI) or Search and Rescue (SAR) information

7.1 MSI or SAR information is promulgated by officially registered information providers whose Certificates of Authorization to broadcast via SafetyNET services are issued by the IMO in accordance with the procedures in Annex 2. Registered information providers include for example:

- .1 NAVAREA Coordinators: for NAVAREA warnings and other urgent safety-related information;
- .2 National Coordinators: for coastal warnings and other urgent safety-related information;
- .3 METAREA Coordinators: for meteorological warnings and forecasts; and
- .4 Rescue Coordination Centres: for shore-to-ship distress alerts, SAR information and other urgent safety-related information.

7.2 All NAVAREA, Sub-area and coastal warnings and METAREA, Sub-area warnings and forecasts should be broadcast only in English in the International SafetyNET Services in accordance with resolution A.706(17), as amended, and A.1051(27) as amended. In addition to the required broadcasts in English, METAREA/NAVAREA, Sub-area and coastal warnings may be broadcast in a national language using a National SafetyNET service.

7.3 Registered information providers shall take into account the need for contingency planning.

Formatert: Utheving

8 Message formatting and C codes for SafetyNET[®]

8.1 EGC messages include instructions to the LES for processing MSI in the form of a special address header that consists of five (or six) C codes as described below. In order for a message to be correctly processed, it shall always consist of data conforming to C codes "1" to "5". Additionally, C code "0" shall be used when required by the service provider.

C₀ Ocean Region code – 1 digit (when required)

0 – Atlantic Ocean Region – West

1 – Atlantic Ocean Region – East

2 – Pacific Ocean Region

3 – Indian Ocean Region

4 – All other Ocean Regions

9 – all eOcean Rregions served by the addressed LES
(Note: availability of C₀ = 9 should be checked with the LES operator or service provider)

C₁ priority code – 1 digit code

C₂ service code – 2 digit code

C₃ address code – 2, 4, 10 or 12 alphanumeric code

C₄ repetition code – 2 digit code

C₅ presentation code – 1 or 2 digit code

Formatert: Utheving

Formatert: Utheving

Formatert: Utheving

Formatert: Engelsk (Storbritannia)

Formatert: Engelsk (Storbritannia)

Formatert: Standardskrift for avsnitt, Skrift: (Standard)
Optima LT Std, 8,5 pkt, Skriftfarge: Svart, Utheving

Formatert: Engelsk (USA)

8 Ref.... for SafetyNET II formatting and codes

C Codes						
C ₀ Ocean Region code (when required)	C ₁ Priority code	C ₂ Service code	C ₃ Address code	C ₄ Repetition code (see annex 4, part E)	C ₅ Presentation code	
1 digit code	1 digit code	2 digit code	2, 4, 10 or 12 alphanumeric code	2 digit code	1 or 2 digit code	
0 – AOR-W	1 – Safety	00 – All ships (general call)	2 digit – 00 (All ships)		Always 0** or 00	
1 – AOR-E	2 – Urgency			Category (a) – for EGC messages to be repeated a finite number of times.		
2 – POR	3 – Distress	04 – Navigational, meteorological or piracy warning or meteorological forecast to a rectangular area	12 alphanumeric rectangular area address D ₁ D ₂ N(S)D ₃ D ₄ D ₅ E(W)D ₆ D ₇ D ₈ D ₉ D ₁₀			Category (b) – for EGC messages to be repeated at specified intervals until cancelled by the MSI provider.
3 – IOR		13 – Navigational, meteorological, coastal or piracy warning or meteorological forecast to a coastal warning area	4 alphanumeric coastal warning area address X ₁ X ₂ B ₁ B ₂			
9 – All Ocean Regions*		14 – Shore-to-ship distress alert to a circular area	10 alphanumeric circular area address D ₁ D ₂ N(S)D ₃ D ₄ E(W)M ₁ M ₂ M			
		24 – Navigational,	10 alphanumeric circular area address			

Formatert: Engelsk (Storbritannia)

	meteorological or piracy warning or meteorological forecast to a circular area	D ₁ D ₂ N(S)D ₃ D ₄ E(W)M ₁ M ₂ M ₃	
	31 – NAVAREA/METAREA, or piracy warning, or meteorological forecast to a NAVAREA/METAREA	2 digit – NAVAREA/METAREA number	
	34 – SAR coordination to a rectangular area	12 alphanumeric rectangular area address D ₁ D ₂ N(S)D ₃ D ₄ D ₅ E(W)D ₆ D ₇ D ₈ D ₉ D ₁₀	
	44 – SAR coordination to a circular area	10 alphanumeric circular area address D ₁ D ₂ N(S)D ₃ D ₄ E(W)M ₁ M ₂ M ₃	

* Subject to availability through LES or service provider

** Value of the presentation code is given by the LES operator or service provider after registration.

8.2 The syntax of the special address header in relation to the exact number of digits and/or alphanumeric characters, and to the spaces between each C code, is critical and must conform to the format required by the LES or service provider used.

8.3 SafetyNET messages are stored at the addressed LES until transmitted the appropriate number of times, as specified by the C₄ code, although the MSI provider may also cancel a message at any time by sending an appropriate cancellation message to the LES.

8.4 Cancellation procedure may vary between different LESs or service providers. Detailed operational procedure is contained in the instructions on sending EGC broadcast given to the MSI providers after registration with the LES operator or service providers.

8.5 Messages destined for areas of satellite overlap that are required to be transmitted through more than one satellite, should be sent to more than one LES (i.e. one in each *satellite Ocean Region*) or multiple Ocean Regions via the same LES to ensure they are received by all intended ships. This may require coordination with adjacent NAVAREA/METAREA and other MSI providers. In an area of overlap coverage from two or three Ocean Region satellites, distress alert relays and urgency warnings will be broadcast over all satellites, which cover the affected region.

8.6 Scheduled broadcasts are made over nominated satellites and at specified times, as allocated by the **IMO International SafetyNET Coordinating Panel**. These schedules are published in national nautical publications and the IMO Master Plan of Shore-Based Facilities for the GMDSS, ~~as amended.~~

8.7 MSI providers shall adhere to their published scheduled broadcast times to facilitate reception of messages.

Formatert: Uttheving

Kommentert [ST31]: WWWWS10, Delete as amended through doc.

9 Monitoring of MSI broadcasts

9.1 In order to ensure the integrity of the MSI being broadcast, MSI providers must monitor the broadcasts which they originate in accordance to IMO resolution A.706(17), as amended. Monitoring is especially important in a highly automated system, which is dependent on careful adherence to procedure and format. This shall be accomplished by the installation of a type approved Inmarsat ~~C or mini-CEGC terminal with EGC SafetyNET~~ receiver to enable each MSI provider to:

- .1 confirm that the message is transmitted and received correctly;
- .2 ensure that cancellation messages are properly executed; and
- .3 observe any unexplained delay in the message being broadcast.

9.2 Type approved Inmarsat EGC receivers only display or print messages on the first occasion they are received. Therefore, in order for MSI providers to confirm that all messages in force are still being transmitted by the SafetyNET services, and that cancelled messages are no longer being transmitted, the EGC receiver used by the MSI provider to monitor their SafetyNET broadcasts should be powered down (including the transceiver), and re-booted at regular intervals, wherever this is possible.

Alternatively, MSI providers should consult their equipment supplier for specialist EGC monitoring ~~software which~~ software, which would not require the MES to be re-booted.

9.3 EGC SafetyNET Log

All type approved Inmarsat EGC receivers C and mini-C MESs capable of receiving MSI, have an EGC SafetyNET Log, which contains information on all SafetyNET service messages received by the terminal.

This information includes:

Message number:	Generated by the terminal
LES <u>or network</u> :	ID of the <u>unique originator</u> LES which transmits the message
Service:	The MES software translates the C ₂ service code used in the message address and displays a short title for the particular type message service.
Priority:	The MES software translates the C ₁ priority code used in the message address and displays the appropriate Priority. This could be either: Safety, Urgency or Distress.
Received date and time:	The date time group YY-MM-DD HH:_mm of when the message was received. A format of the date is configurable by the MES operator.
Size:	Usually in number of bytes or characters.
Sequence number:	The unique message sequence or reference number allocated to the message by the addressed LES <u>or network</u> .
Routing:	Message routeing (memory or memory and printer) – set up by the MES operator or a mandatory routeing for Urgency and Distress priority messages.

Message number	LES	Service	Priority	Received date and time	Size	Sequence number	Routeing
14022405.egc	321	MET/NAV warning/forecast	Safety	14-02-24 03:31	2263	1605	Mem
14022402.egc	321	SAR coordination	Urgency	14-02-24 03:02	1506	1604	Prn+Mem
14022401.egc	322	Coastal warning/forecast	Safety	14-02-23 02:56	269	9154	Mem
14022302.egc	304	Distress alert relay	Distress	14-02-23 20:44	769	691	Prn+Mem
14022305.egc	317	NAV warning	Safety	14-02-23 19:41	819	8318	Mem
14022302.egc	322	MET warning	Safety	14-02-23 19:35	2358	9150	Mem

Formatert: Utheving

Figure 8 – Example of an EGC SafetyNET services ILog

Formatert: Utheving

10 Quality control of MSI broadcasts

10.1 Misuse of C codes

Monitoring of MSI broadcasts is a vital tool to show instances of misuse of C_1 (priority), C_2 (service) and C_4 (repetition) codes and other technical or operational problems in connection with preparing and broadcasting EGC messages. Misuse of C codes results in incorrect understanding of MSI services and types of message, multiple reception of unwanted messages received on ships and delay in receiving vital information.

10.2 Improper use of C_1 priority codes

This refers mainly to the use of service code $C_2 = 14$ "Ship-to-Shore distress alerts" which require using $C_1 = 3$ Distress priority code only. Problems are caused when the service code $C_1 = 2$ is used by mistake, as in the following example. When $C_1 = 2$ is erroneously used in conjunction with $C_2 = 14$, the header of the message received on a ship is displayed and printed as:

LES xxx – MSG 1210 – Distress Urgent Call to Area:
14N 66W 300 – PosOK

where:

LES xxx – ID of the LES;

MSG 1210 – message number;

Distress Call to Area – decoding of service $C_2 = 14$;

Urgent – decoding of priority $C_1 = 2$;

14N 66W 300 – circular area the message was sent to, where 14N 66W is centre of the circle and 300 is radius of the circle in nautical miles; and

PosOK – indicator that the MES's position status is valid or the position was updated within the last 12 hours.

The message header contains reference to two different priorities at the same time – Distress and Urgent (the same problem may be evident in the EGC log or message list), which misleads mariners about the message importance and its content. This is an important issue, particularly for non-SOLAS users, where an EGC message received with conflicting Urgency and Distress priorities may NOT be printed out automatically, which could cause a delay in reacting to the vital information.

If an EGC message is submitted with Urgency priority, service code $C_1 = 2$ and another message is sent with Distress priority afterwards, priority code $C_1 = 3$, the message with Urgency priority will be aborted and the message with Distress priority will be handled first.

10.3 Improper use of C_2 service codes

There are cases when MSI providers submit an EGC SafetyNET message using improper C_2 service codes and a sample is given below:

```
LES xxx – MSG 5213 – Met/NavWarn Urgent Call to Area:  
35N 23E 300 – PosOK  
FROM: Maritime Rescue Coordination Centre xxx  
TO: ALL SHIPS IN xxx
```

```
SAR SITREP NO: 02
```

```
FISHING BOAT 'xxx' WITH THREE PERSONS ON BOARD  
DEPARTED FROM xxx ISLAND ON xxx AT NOONTIME AND SINCE  
THEN NO INFORMATION ABOUT HER. PARTICULARS ... SHIPS  
SAILING IN VICINITY ARE KINDLY REQUESTED TO KEEP A  
SHARP LOOK OUT INFORMING MRCC  
REGARDS  
DUTY OFFICER
```

The message was sent using service code $C_2 = 24$ "Met/Nav warning to circular area", as shown in the message header, but the text of the message content is concerned with SAR coordination. The correct C_2 code for this type of message should have been $C_2 = 44$ "SAR Coordination to a circular area". Use of the incorrect C_2 codes may delay delivery of the vital SAR information.

Another example is the improper use of rectangular addressing, e.g., service code $C_2 = 04$, for coastal warnings whereby the addressed rectangular area covers areas far beyond coastal areas. In this case, ships receive unwanted information for areas other than those in which

they are navigating.

Reception of EGC SafetyNET coastal warnings is an option and to receive these messages, MESs should be programmed or set up accordingly; otherwise coastal warnings will not be received, regardless of the ship's position. If a coastal warning-type message is addressed to a rectangular area, **ALL** ships, whose position is inside the addressed rectangle, will receive the message. The main problem here is not only misusing service codes, which are specified by the International SafetyNET Manual, but reception (and printing) of multiple unwanted messages which ships may never require.

10.4 Improper use of C₄ repetition codes

Repetition codes detailed in [aAnnex 4](#), part E, are used by MSI providers to "instruct" the Inmarsat C system to repeat a SafetyNET message a finite number of times or at specific intervals until cancelled by the information provider.

MSI is submitted for broadcast with repetitions, either six min after initial broadcast (with six min "echo") or every 1, 2, 3, 4,... 48,... or 120 hours until cancelled by the MSI provider. Each message, when submitted for broadcast, is given a unique reference number. When the message is received by the MES, the reference number is "recorded" by the mobile terminal and stored in the memory. When the same message is re-broadcast later, using any C₄ repetition codes, MESs receive it and "recognize" the reference number by [cross-checkingcross-checking](#) the list of numbers of messages already received. Messages received with the same unique reference number will not be displayed or printed out for a second time.

Note: An EGC message, which requires a multiple broadcast, should be addressed with the proper repetition code and requires only a single submission to the LES. The process of repeated broadcast will be controlled by the repetition code.

When the same SafetyNET message is submitted for broadcast for a second (or third or more) time, the addressed LES will give the message **another** reference or sequence number and mobile terminals will not be able to "recognize" it as the same message. In this [casecase](#), each subsequent message submitted to the LES for repetition will be received by MESs and may be automatically printed out.

SafetyNET monitoring shows that some MSI providers do not use the

recommended repetition code and in this easecase, MESs receive and print unwanted messages, which will fill up the MES's memory rather quickly and waste printing paper.

Notes:

1. Some MSI is broadcast only once on receipt using repetition code C₄ = 01.

2. Mariners are advised not to engage in routine communications during the periods designated for scheduled MSI SafetyNET broadcasts. The six min repeat or echo should be used for non-scheduled broadcasts.

Below is an example of the same weather forecast submitted for broadcast twice and having two different reference numbers:

LES xxx – MSG 1032 – MetWarn/Fore Safety Call to Area:
xxx – PosOK
xxx CSAT 23423440010402 xx-NOV-2016 09:55:41 103000
SECURITE
HIGH SEAS BULLETIN FOR METAREA xxx ISSUED AT 0800
ON xx NOV 2019 BY THE MET OFFICE ...

Formatert: Utheving

Formatert: Utheving

LES xxx – MSG 1033 – MetWarn/Fore Safety Call to Area:
xxx – PosOK
xxx CSAT 23423440010402 xx-NOV-2016 10:10:13 103453
SECURITE
HIGH SEAS BULLETIN FOR METAREA xx ISSUED AT 0800
ON xx NOV 2019 BY THE MET OFFICE

Formatert: Utheving

Formatert: Utheving

The message (size about 4,800 characters) was received and printed twice since it was submitted to the LES for broadcast twice and was given two separate reference numbers – 103000 and 103453.

If the message had been submitted once with, for example C₄ = 11 (transmit on receipt followed by repeat six minutes later), it would have been given one reference number and received and printed only once.

11 Accessing the SafetyNET service

11.1 MSI messages are transmitted to LESs providing Inmarsat C services in accordance with national and international routing arrangements. Access to different LESs may require use of different user interfaces that may have different access procedures and syntax commands and it should be checked with the Inmarsat C LES operator or service provider.

11.2 Some LESs may provide e-mail, or internet (direct) drop access to the SafetyNET service that allows registered MSI providers to send EGC messages using e-mail from any computer with access to the internet. Due to the nature of the internet, an e-mail service may not guarantee that EGC messages will be received by the addressed LES without delay and may not support cancellation procedures. For this reason, monitoring of all EGC messages is especially important in accordance with section 9 above. For accessing the SafetyNET II serviceservice, see Annex 6. p.---

Formatert: Utheving

Formatert: Utheving

Formatert: Utheving

12 Land Earth Station functions

12.1 Messages for transmission via the SafetyNET service are received and processed automatically at the LES. Because the system is automatic, the quality of service and information depends on accurate preparation of messages.

12.2 Messages are not reviewed for corruption or accuracy at the LES; therefore, the originator must take special care to adhere to the format specified. This dependence on syntax is one of the reasons why MSI providers must monitor the broadcasts they originate.

12.3 Participating LESs transmit SafetyNET messages over an inter-station signalling link to the Ocean Region Network Coordination Station (NCS) in the relevant Ocean Region for transmission over the broadcast channel.

12.4 Messages will be queued at the LES and scheduled for transmission according to priority and instructions contained in the special address headers (C_1 – priority code and C_4 – repetition code); messages with the highest priority will be transmitted first (i.e. in the order "distress", "urgency", "safety"). The originator of each message will specify in the address field the desired number of repetitions and the interval between transmissions for that message.

13 Receiving SafetyNET service broadcasts

13.1 The basic requirements of the EGC receiver are that it should continuously receive the broadcast channel (~~the Inmarsat C NCS common signalling channel~~) and process the messages being transmitted through the satellite. However, certain classes of receiving equipment may not provide wholly uninterrupted monitoring of the broadcast channel, for example, the receiver was tuned to an LES messaging channel to receive or transmit a message and initial broadcast was missed. For this reason, MSI providers shall repeat their most important **unscheduled messages** six minutes after the first broadcast so that the terminal would receive EGC messages on the repeated broadcast.

13.2 Although the MES receives all SafetyNET messages on the broadcast channel, it may suppress some messages from being displayed or printed automatically. For example:

- .1 all messages addressed to geographical areas (circular or rectangular) other than those including the ship's current position will be automatically suppressed;
- .2 for coastal warnings only (see ~~f~~Figure 8) it may be programmed to suppress:
 - a) messages containing B₁ codes for coastal warning areas which have not been set up in the terminal,
 - b) messages containing B₂ codes for subject matter of no relevance to the ship.

13.3 The MES also suppresses the printing of messages previously received. It is not possible to reject mandatory "all ship" messages such as shore-to-ship distress alerts for the area within which the ship is located. When a distress or urgency message is received, an audio and visual alarm will be given.

13.4 The following B₂ code subject indicators for coastal warnings are in use:⁹

A = Navigational warnings*	I = not used					
B = Meteorological warnings*	J = SATNAV messages					
C = Ice reports	K = Other electronic navaid messages					
D = Search and <u>R</u> escue information, and acts of piracy warnings*	L = Other navigational warnings – additional to B ₂ code A					
E = Meteorological forecasts	<table border="1"> <tbody> <tr> <td>V =</td> <td rowspan="4">Special services allocation by the International SafetyNET Coordinating Panel</td> </tr> <tr> <td>W =</td> </tr> <tr> <td>X =</td> </tr> <tr> <td>Y =</td> </tr> </tbody> </table>	V =	Special services allocation by the International SafetyNET Coordinating Panel	W =	X =	Y =
V =		Special services allocation by the International SafetyNET Coordinating Panel				
W =						
X =						
Y =						
F = Pilot service messages						
G = AIS						
H = LORAN messages						
	Z = No messages on hand					

Formatert: Utheving

13.5 It is recommended that, in order to ensure that all necessary MSI is available before sailing, the EGC receiver should remain in operation while the ship is in port.

⁹ Cannot be rejected by the receiver.

13.6 Although the reception of SafetyNET traffic-service broadcasts are automatic, the shipboard operator must set up the receiver properly before the start of the voyage as follows:

- .1 Selecting the appropriate satellite eOcean fRegion if the ship is navigating in an overlap area of two or three satellites.
- .2 Selecting one or more of the following (as appropriate):
 - a) current NAVAREA/METAREA or Sub-area designator.
On some MES models this function is automatic, on others manual, and it requires an initial setup of the current NAVAREA/METAREA. When this ship moves to another area, a new setup should again be performed manually. Please check with the manufacturer's handbook.
 - b) additional NAVAREA/METAREA designator(s);
 - c) relevant coastal warning area identification letter and subject indicator characters;
 - d) fixed position(s).

EGC Setup

EGC-only receiver System Messages

Additional Navarea(s)/Metarea(s) [0...99]

Coastal Warning Settings

Coastal Warning Areas [A...Z]

Type of Coastal Warnings

Navigational Warnings Meteorological Forecasts Satnav

Meteorological Warnings Pilot Service messages Other Nav aids

Ice Reports Lorán messages Additional Nav Warnings

Search and Rescue AIS messages

Fixed Position Settings

	Deg	N/S	Deg	E/W
Fixed Pos. 1	50	N	009	W
Fixed Pos. 2	35	N	020	W
Fixed Pos. 3	11	N	057	E
Fixed Pos. 4	05	S	120	W
Fixed Pos. 5				

Formatert: Kontroller staving og grammatikk

Figure 9 – *Example of an EGC setup screen*

Note: Figure 9 depicts the general information available on an EGC setup screen. The layout of this screen varies between different models of type approved Inmarsat C and mini-C MES terminals.

13.7 The position information in MESs is up-dated automatically from integrated navigational receivers and they are fitted on all modern (latest) terminals, or may be up-dated from a separate electronic position-fixing system. If there is no automatic position up-date system installed, e.g. on older MES terminals, it is recommended that the position in the MES is up-dated at least every 4 hours. If the position has not been up-dated for more than 12 hours or is unknown, all SafetyNET messages within the entire satellite Ocean Region will be printed or stored in the MES.

13.8 The majority of Inmarsat C MES terminals with EGC reception capability are Class 2 Inmarsat C terminals (having a common receiver for Inmarsat C messages and MSI) and MSI broadcasts will only be received when the terminal is idle. Therefore, Class 2 terminals shall not be in use for other communications at the times of scheduled broadcasts. Similarly, in the case of Class 3 Inmarsat C MES (having

two separate receivers for Inmarsat C messages and MSI), it is necessary to ensure that it is tuned to the broadcast channel of the appropriate satellite at the times of scheduled broadcasts.

Note: More information on different classes of Inmarsat C and Mini-C MESSs is in Annex 5.

14 Charges for SafetyNET services

14.1 IMO Resolution A.707(17): *Charges for Distress, Urgency and Safety Messages Through the Inmarsat System*, establishes the arrangements in place for the treatment of charges.

14.2 There are no charges to the mariner for reception of SafetyNET messages.

14.3 Message transmission charges apply to MSI providers and are set at a special SafetyNET tariff by national telecommunication service providers and LESSs offering EGC services.

Annex 1

International SafetyNET Coordinating Panel

Formatert: Uttheving

1 Terms of reference

To coordinate the development and use of the International SafetyNET Service, and in particular to:

- .1 develop operating methods for the effective use of the SafetyNET service, including consideration of the need for scheduled broadcasts;
- .2 develop documentation in support of the SafetyNET service, in particular the International SafetyNET Manual;
- .3 advise Land Earth Station (LES) operators and potential registered information providers on all aspects of the Service, including system access and effective operation;
- .4 develop criteria and establish means for the approval and registration of potential information providers;
- .5 coordinate the registration of potential information providers; and
- .6 promote a proper understanding of the benefits and use of the International SafetyNET Service among the wider maritime community.

Kommentert [ST32]: WWWWS10, Peter and David will work separate submission to NCSR 6.

2 Contact address

The International SafetyNET Coordinating Panel can be contacted at the following address:

The Chairman
International SafetyNET Coordinating Panel
International Maritime Organization
4 Albert Embankment
London SE1 7SR
United Kingdom
Telephone: +44 (0)20 7735 7611, Fax: +44 (0)20 7587 3210
E-mail: ncsr@imo.org (In subject line add: for Chairman IMO
International SafetyNET Coordinating Panel)

Formatert: Uttheving

Feltkode endret

3 Panel membership

3.1 The International SafetyNET Coordinating Panel is open to membership by all Member Governments ~~and also~~ includes one member nominated by each of the following international organizations:

- i) International Maritime Organization (IMO)
- ii) World Meteorological Organization (WMO)
- iii) International Hydrographic Organization (IHO)
- iv) International Mobile Satellite Organization (IMSO)

3.2 The following may be represented as observers on the panel:

- i) IHO World-Wide Navigational Warnings Service Subcommittee
- ii) IMO NAVTEX Coordinating Panel
- iii) ~~Expert Team on Maritime Safety Services, JCOMM World-Wide Met-Ocean Information and Warning Service Committee, (ETMSS) of the Joint WMO/IOC Technical Commission for Oceanography and Marine Meteorology (JCOMM)~~
- iv) ~~Immarsat~~ **Recognized mobile satellite service providers**

Formatert: Utheving

Formatert: Utheving

Kommentert [ST33]: WWNWS10

Formatert: Utheving

Annex 2
Authorization, certification and registration
of SafetyNET information providers

Two distinct and separate processes, Authorization and Certification, must be completed before an information provider will be granted Registration to access the SafetyNET broadcast service. They have been established to protect the integrity of the SafetyNET information service and clearly establish a qualification to the special SafetyNET tariff.

1 Authorization

1.1 Authorization is carried out by IMO in consultation with IHO and WMO as appropriate.

1.2 In order to obtain authorization to broadcast maritime safety information through the International SafetyNET Service, an information provider must apply to the relevant international organization for approval to participate in the internationally coordinated service:

Meteorological authorities – to WMO;

Hydrographic authorities – to IHO;

Search and Rescue authorities – to IMO;

The International Ice Patrol – to IMO;

Others – to IMO.

1.3 In considering such applications, the relevant international organizations will take into account:

- .1 the established and expected availability of other information sources for the area concerned; and
- .2 the need to minimize duplication of information as much as possible.

1.4 The relevant international organization will inform IMO of endorsed applications.

2 Certification

2.1 On receipt of IMO authorization, the International SafetyNET

Coordinating Panel will issue a Certificate of Authorization to Participate in the International SafetyNET Service directly to the information provider with a copy to IHO or WMO or IMO, as well as to Inmarsat C LES operators. A specimen Certificate of Authorization is shown at the end of this [Annex](#).

2.2 **International SafetyNET Coordinating Panel** will maintain the master list of all registered information providers and circulate it to IMO, IHO, WMO and all Inmarsat C LES operators.

Formatert: Uttheving

3 Registration

3.1 After receiving a Certificate of Authorization, an information provider may conclude an agreement with any Inmarsat C LES operator(s), serving the required **Ocean Region(s)**, to obtain access to the system.

3.2 This will involve, in addition to the contractual aspects, registration of the information provider's ~~identity~~ **identity, which** must be programmed into the LES control equipment.

3.3 LES operators will only register information providers who have received a Certificate of Authorization.

4 Contact addresses

International Maritime Organization

The Chair~~man~~

International SafetyNET Coordinating Panel

4 Albert Embankment
London SE1 7SR
United Kingdom

Formatert: Uttheving

Telephone: +44 (0)20 7735 7611

Fax: +44 (0)20 7587 3210

E-mail: ncsr@imo.org (In subject line add: for Chair~~man~~ IMO)

Formatert: Engelsk (Storbritannia)

International SafetyNET Coordinating Panel

Feltkode endret

Formatert: Uttheving

International Hydrographic Organization

4b quai Antoine 1er
BP445
MC98011 Monaco Cedex
Principauté de MONACO

Telephone: +377 93 10 81 00
Fax: +377 93 10 81 40
E-mail: info@iho.int

World Meteorological Organization

7bis, avenue de la Paix
Case postale 2300
CH-1211 Geneva 2
Switzerland

Telephone: + 41(0) 22 730 81 11
Fax: + 41(0) 22 730 81 81
E-mail: mmo@wmo.int

Feltkode endret

Formatert: Engelsk (Storbritannia)

Formatert: Engelsk (Storbritannia)

5 Sample Certificate of Authorization

Kommentert [ST34]: Pete provide new

4 Albert Embankment, London SE1 7SR United Kingdom	99 City Road, London EC1Y 1AX United Kingdom

[Name of authority/country]

Date: 01 Jan 2019⁸

Certificate of Authorization to Participate as an Information Provider in the International SafetyNET Service

This is to certify that the [Name of authority/country] is authorized by the International Maritime Organization to provide navigational warning services for broadcast in the International SafetyNET Service in accordance with annex 2 of the International SafetyNET Manual.

PETER M. DOHERTY

Chairman

International SafetyNET Coordinating Panel

Formater: Utheving

Certificate No.	"XX"
International Maritime Organization (IMO)	International Mobile Satellite Organization (IMSO)
Telephone: National (207) 735-7611 International +44 (207) 735-7611 Facsimile +44 (207) 587-3210	Telephone: National (0) 20 3970 1060 (207) 728-1248 International +44 (0) 20 3970 1060 (207) 728-1248 Facsimile +44 (207) 728-1172

Formater: Utheving

Formater: Utheving

Kommentert [DJ35]: Update

Formater: Utheving

Formater: Utheving

Annex 3
The Inmarsat system

Formatert: Uttheving

1 Introduction

- 1.1 There are three essential components of the Inmarsat system:
- .1 the Inmarsat space segment – the satellites and their ground support facilities – planned and funded by Inmarsat;
 - .2 the ground segment – comprises a network of Land Earth Stations (LESs), Network Coordination Stations (NCSs) and the Network Operations Centre (NOC). Each LES provides an interface between the space segment and the national and international fixed telecommunication networks; and
 - .3 the Mobile Earth Stations (MESs) – comprises mobile satellite communication terminals.

2 Bandwidths

2.1 Shore-to-ship communications are in the 6 GHz band (C-band) from the LES to the satellite and in the 1.5 GHz band (L-band) from satellite to ship. Ship-to-shore communications are in the 1.6 GHz band (L-band) from the ship to the satellite and in the 4 GHz band (C-band) from satellite to LES.

3 The space segment

3.1 To provide the space segment for global coverage, Inmarsat employs its own dedicated satellites.

Satellite Ocean Region	Satellite	Terminals
AOR-E (Atlantic Ocean Region East)	AOR-E	Inmarsat C and Mini C
AOR-W (Atlantic Ocean Region West)	AMER	Inmarsat C, Mini C and Fleet Safety
POR (Pacific Ocean Region)	APAC	Inmarsat C, Mini C and Fleet Safety
IOR (Indian Ocean Region)	EMEA	Inmarsat C, Mini C and Fleet Safety
MEAS (Middle East and Asia)	MEAS	Fleet Safety

Kommentert [ST36]: WWNWS10, review.

Formatert: Uttheving

Kommentert [ST37]: WWNWS10, Dana to check.

Formatert: Uttheving

Formatert: Uttheving

Formatert: Uttheving

Formatert: Uttheving

Formatert: Uttheving

3.2 The space segment is segmented globally into four **ocean Regions**: Atlantic Ocean Region East (AOR-E), Atlantic Ocean Region West (AOR-W), Indian Ocean Region (IOR) and Pacific Ocean Region (POR). Each **ocean Region** is served by a dedicated satellite. Inmarsat has full contingency plans in place in the unlikely event of any prime satellite outage. These plans are exercised regularly and are witnessed by the International Mobile Satellite Organization (IMSO). The Polar Regions – above approximate latitudes 76° N and 76° S – cannot be seen by geostationary satellites (see **Figures 3 and 4**).

4 The ground segment

4.1 The Inmarsat system is connected into the **world-wide/worldwide** telecommunication networks via LESs. Many of these LESs provide Inmarsat C EGC services.

4.2 For Inmarsat C communication system there is a Network Coordination Station (NCS) in each **ocean Region**, which monitors and controls communications traffic within its region. Each NCS communicates with the LESs in its **ocean Region**, the other NCSs and the Network Operations Centre (NOC). Inmarsat C NCSs also transmit EGC SafetyNET and FleetNET messages on the NCS common channel.

4.3 The Inmarsat Network Operations Centre (NOC) is located in London at the Inmarsat headquarters and functions around the clock, coordinating the activities of the NCSs and the LESs in each **ocean Region**.

5 Mobile Earth Stations (MESs)

5.1 Inmarsat C and **Mini-C** MESs with the EGC function are small, lightweight terminals, with small omni-directional antennas, for providing data and message-type services. EGC receive capability is provided by Class 2 or 3 Inmarsat C MESs. Interfaces via RS232 ports are provided for a dedicated messaging unit, personal computer or any other data terminal equipment for message generation and display.

5.2 Class 0 standalone EGC receivers provide the capability to receive SafetyNET and FleetNET messages only; there is no transmit or receive capability for sending and receiving messages.

5.3 The technical requirements of all classes of equipment are detailed

in Annex 5.

← **Formatert:** Mellomrom Før: 24 pkt.

Annex 4

Operational guidance *for SafetyNET services*

1 This annex contains operational guidance for the benefit of registered MSI providers who are responsible for preparing messages for broadcast via the ~~International~~ SafetyNET Services. **See Annex xxx6 for SafetyNET II.**

Use of the codes given in this annex is mandatory for all messages in the system.

2 Types of messages and message formats are detailed in the sub-parts of this annex.

- Part A – Navigational warning service
- Part B – Meteorological service
- Part C – Search and Rescue (SAR) services and SAR coordination traffic
- Part D – Piracy countermeasures broadcast messages

Allocation of priority and service codes for EGC SafetyNET services		
EGC SafetyNET service	Message priority	Service code (type)
Navigational warning services	C ₁ = 1 (Safety) – normally C ₁ = 2 (Urgency) – exceptionally at discretion of MSI provider	C ₂ = 04 – Navigational warning to a rectangular area C ₂ = 13 – Coastal warning to a coastal warning area C ₂ = 24 – Navigational warning to a circular area C ₂ = 31 – NAVAREA warning to a NAVAREA
Meteorological services	C ₁ = 1 (Safety) – always for forecasts and warnings	C ₂ = 04 – Meteorological warning or forecast to a rectangular area

Formatert: Uttheving

Formatert: Uttheving

Formatert: Uttheving

	C ₁ = 2 (Urgency) – always for urgent tropical cyclone warnings only	C ₂ = 13 – Meteorological warning or forecast to a coastal warning area C ₂ = 24 – Meteorological warning or forecast to a circular area C ₂ = 31 – METAREA warning or meteorological forecast to a METAREA
SAR services: 1) shore-to-ship distress alert	C ₁ = 3 (Distress) – always	C ₂ = 14 – Shore-to-ship distress alert to a circular area
2) SAR coordination traffic	C ₁ = 1 (Safety) – determined by the phase of emergency C ₁ = 2 (Urgency) – determined by the phase of emergency C ₁ = 3 (Distress) – determined by the phase of emergency	C ₂ = 34 – SAR coordination to a rectangular area C ₂ = 44 – SAR coordination to a circular area
3) shore-to-ship urgency and safety traffic	C ₁ = 1 (Safety) C ₁ = 2 (Urgency)	C ₂ = 31 – Urgency and safety traffic
4) general (all ships call within the Inmarsat Ocean Region)	C ₁ = 2 (Urgency) C ₁ = 3 (Distress)	C ₂ = 00
Piracy countermeasures broadcast messages	C ₁ = 1 (Safety) C ₁ = 2 (Urgency) – for piracy attack warnings	C ₂ = 04 – Piracy warning to a rectangular area C ₂ = 13 – Piracy warning to a coastal warning area C ₂ = 24 – Piracy warning to a circular area C ₂ = 31 –

		Piracy warning to a NAVAREA
--	--	-----------------------------

3 The broadcast parameters are controlled by the use of five (or six) C codes which are combined into a generalized message address header format as follows:

$C_0:C_1:C_2:C_3:C_4:C_5$

(Spaces, colons or other delimiters between these codes will be required, depending on the communication protocol of the addressed LES.)

C_0 – Ocean region

C_1 – Message priority

C_2 – Service code

C_3 – Address code

C_4 – Repetition code

C_5 – Presentation code

Each C code controls a different broadcast parameter and is assigned a numerical value according to the options specified in the following parts.

The additional C_0 code will only be required to identify the satellite Ocean Region when sending a broadcast message to a LES which operates to more than one satellite Ocean Region, as follows:

$C_0 = 0$ – AOR-W

$C_0 = 1$ – AOR-E

$C_0 = 2$ – POR

$C_0 = 3$ – IOR

$C_0 = 9$ – All Ocean Regions¹⁰

Formatert: Engelsk (Storbritannia)

Formatert: Engelsk (Storbritannia)

¹⁰ Subject to availability through LES or service provider.

- 4 (a) All EGC messages should comprise of three elements:
 Address header instruction (EGC C codes)
 TEXT OF MESSAGE
 NNNN

Mandatory message element table	
Message element	Remarks
Address header instruction	The syntax of the special address header in relation to the exact number of digits and/or alphanumeric characters, and to the spaces between each C code is critical, and must conform to the format required by the LES or service provider as supplied in their specific instruction manual.
TEXT OF MESSAGE	The content of the message should be presented in UPPER case. For maritime safety information messages, the format of navigational warnings is defined in the <i>Joint IMO/IHO/WMO Maritime Safety Information Manual</i> , as amended.
NNNN	The letters NNNN should be inserted at the end of the text to indicate "end of message".

- (b) EGC messages submitted for transmission (or broadcast) via a ~~two-stage~~two-stage access system must also include an end of transmission instruction code for the LES. This should be inserted on the final line, after NNNN. This code may vary, and must conform to the format required by the LES or service provider as supplied in their specific instruction

manual.

5 The International Maritime Organization (IMO) requires that, in order to allow the use of non-dedicated receive facilities, the majority of broadcasts on the International SafetyNET Service are made at scheduled times. Broadcast schedules must be coordinated through the International SafetyNET Coordinating Panel, which can also offer advice on ways of scheduling information within the system.

6 Because errors in the header format of a message may prevent it being released, MSI providers must install an Inmarsat SafetyNET receiver and monitor broadcasts of messages_ which they originate.

7 For all the services described below, a cancellation or deleting facility is provided for messages transmitted to a LES with category (b) repetition codes (see part E). Cancellation (or deletion) procedures may vary between different LESs or service providers. Detailed operational procedure is contained in the instructions on sending EGC broadcasts given to the MSI providers after registration with the LES operator or service provider.

8 The term "echo" used in all of the services described below in parts A, B, C and D, is associated with using the respective C₄ repetition codes which will initiate an automatic repeated broadcast six min after the initial scheduled or unscheduled broadcast. The six min repeat or echo is used to ensure that the warning is received by the maximum number of ships.

Part A – Navigational warning services

1 The following guidelines set out the arrangements to be used for promulgating navigational and coastal warnings via SafetyNET for the GMDSS. **They are mandatory for broadcasts in the International SafetyNET Service. Broadcasts originated by the International Ice Patrol also follow the guidelines in this part.**

2 These guidelines are to be read in conjunction with the IMO/IHO World-Wide Navigational Warning Service (WWNWS) Guidance Document, resolution A.706(17), as amended.

3 Navigational warnings that require an immediate broadcast should be transmitted as soon as possible after receipt. If still in force, they should be repeated in subsequent scheduled broadcasts, twice a day for six weeks or until cancelled.

4 Navigational warnings shall remain in force until cancelled by the originating Coordinator. Navigational warnings should be broadcast for as long as the information is valid; however, if they are readily available to mariners by other official means, for example in Notices to Mariners, then after a period of six weeks they may no longer be broadcast. If the navigational warning is still valid and not available by other means after six weeks, it should be re-issued as a new navigational warning.

5 The following C codes shall be used for warnings issued under the auspices of the WWNWS.

5.1 C₁ – Message priority

C ₁ = 1 (safety)
C ₁ = 2 (urgency) (at discretion of the registered MSI provider)

5.2 C₂ – Service code¹¹

C ₂ = 04	Navigational warning to a rectangular area*
C ₂ = 13	Coastal warning to a coastal warning area
C ₂ = 24	Navigational warning to a circular area
C ₂ = 31	NAVAREA warning to a NAVAREA

5.3 C₃ – Address code

C ₃ = two digits X ₁ X ₂	When C ₂ = 31, then:
---	---------------------------------

¹¹ Until Inmarsat -C or mMini -C terminals operating in arctic waters have been updated or replaced, C₂ = 04 may be used for NAVAREA warnings to a rectangular area by NAVAREAs XVII, XVIII, XIX, XX and XXI.

	X ₁ X ₂ are the two digits of the NAVAREA number (with a leading zero where necessary in the range 01 – 21).
C ₃ = four alphanumeric characters X ₁ X ₂ B ₁ B ₂	When C ₂ = 13 for Coastal warnings, then: X ₁ X ₂ are the two digits of the NAVAREA number (with a leading zero where necessary in the range 01 – 21) B ₁ is the coastal warning area A to Z B ₂ is the subject indicator and must always be A or L, where: A = Navigational warnings L = Other navigational warnings
C ₃ = twelve alphanumeric characters D ₁ D ₂ LaD ₃ D ₄ D ₅ LoD ₆ D ₇ D ₈ D ₉ D ₁₀	When C ₂ = 04 for NAVAREA warnings within a rectangular area: D ₁ D ₂ is latitude of south-west corner of the rectangle in degrees La is hemisphere which will always be N for Arctic NAVAREAs XVII to XXI D ₃ D ₄ D ₅ is longitude of south-west corner of rectangle in degrees, with leading zeros if required Lo is longitude E or W D ₆ D ₇ is extent of rectangle in latitude (degrees) D ₈ D ₉ D ₁₀ is extent of rectangle in longitude (degrees)
Example: a rectangle whose south-west corner is 60°N and 010°W, extending 30° north and 25° east, is coded as: 60N010W30025	
Note: Latitude and longitude are limited by values from 00° to 90° latitude and 000° to 180° longitude.	

5.4 C₄ – Repetition code

C ₄ = 01	May be used for initial unscheduled broadcast of NAVAREA warnings, and coastal warnings with no echo (transmit once on receipt)
---------------------	---

C ₄ = 11	Recommended for use with initial unscheduled broadcast of NAVAREA warnings, and coastal warnings (transmit on receipt, echo six min later)
C ₄ = 16	Use for NAVAREA or coastal warnings scheduled for broadcast twice per day at 12 hour intervals with safety priority
Note: For NAVAREA or coastal warnings scheduled for broadcast more than twice per day, the appropriate C ₄ repetition code detailed in part E of this Manual must be used.	

5.5 C₅ – Presentation code

C ₅ = 00	The code 00 for International Alphabet Number 5 is normally used
---------------------	--

Part B – Meteorological services

Formatert: Uttheving

1 The following guidelines set out the arrangements to be used for promulgating meteorological forecasts and warnings via SafetyNET for the GMDSS. **They are mandatory for broadcasts in the International SafetyNET Service.**

2 These guidelines are to be read in conjunction with the WMO Manual on Marine Meteorological Services (WMO No. 558), as revised for the GMDSS.

3 In order to ensure uniformity of meteorological forecasts and warnings globally, the following C codes should be used for meteorological services via SafetyNET.

3.1 C₁ – Message priority

C ₁ = 2 (urgency)	Only use for tropical cyclone warnings or urgent meteorological warnings with force 12 Beaufort or above
------------------------------	--

C ₁ = 1 (safety)	For forecasts and other meteorological warnings
-----------------------------	---

3.2 C₂ – Service code¹²

C ₂ = 04	Meteorological warning or forecast to a rectangular area*
C ₂ = 13	Meteorological warning or forecast to a coastal warning area
C ₂ = 24	Meteorological warning or forecast to a circular area
C ₂ = 31	METAREA warning or meteorological forecast to a METAREA

3.3 C₃ – Address code

C ₃ = ten alphanumeric characters D ₁ D ₂ LaD ₃ D ₄ D ₅ LoR ₁ R ₂ R ₃	When C ₂ = 24 for meteorological warnings to user defined circular area, then: D ₁ D ₂ La (three characters) is latitude of centre in degrees, and La whether north (N) or south (S). A leading zero should be used for latitudes less than 10° D ₃ D ₄ D ₅ Lo (four characters) is longitude of centre in degrees, and Lo whether east (E) or west (W) of the prime meridian. One or two leading zeros should be used for longitudes less than 100° R ₁ R ₂ R ₃ (three characters) is radius of circle in nautical miles, up to 999. One or two leading zeros should be used for radius less than 100 nm
Example: A circle centred at latitude 56°N longitude 34°W with radius of 35 nautical	

¹² Until Inmarsat -C or mMini.-C terminals operating in arctic waters have been updated or replaced, C₂ = 04 may be used for METAREA warnings or meteorological forecasts to a rectangular area by METAREAs XVII, XVIII, XIX, XX and XXI.

miles is coded as: 56N034W035	
C ₃ = two digits XX	When C ₂ = 31, then: C ₃ = the two digits of the METAREA number (with a leading zero where necessary in the range 01 – 21)
C ₃ = four alphanumeric characters X ₁ X ₂ B ₁ B ₂	When C ₂ = 13 for coastal warnings, then: X ₁ X ₂ are the two digits of the METAREA number (with a leading zero where necessary in the range 01 – 21). B ₁ is the coastal warning area A to Z B ₂ is the subject indicator and must always be B or E, where: B = Meteorological warnings E = Meteorological forecasts
C ₃ = twelve alphanumeric characters D ₁ D ₂ LaD ₃ D ₄ D ₅ LoD ₆ D ₇ D ₈ D ₉ D ₁₀	When C ₂ = 04 for meteorological warnings or forecasts within a rectangular area Note: The definition of 12 characters for a rectangular address is given in part A, paragraph 5.3

3.4 C₄ – Repetition code

Category (a) repetition codes are used for meteorological services as follows:	
C ₄ = 01	Use for meteorological forecast (transmit once on receipt)
C ₄ = 11	Use for meteorological warning (transmit on receipt followed by repeat six min later)

3.5 C₅ – Presentation code

C ₅ = 00	The code 00 for International Alphabet Number 5 is normally used.

--	--

Part C – Search and Rescue services

1 The following guidelines set out the arrangements to be used by Rescue Coordination Centres (RCCs) for initiating transmission of shore-to-ship distress alert relays and shore-to-ship Search and Rescue information. Transmissions should be in accordance with the relevant procedures of the International Telecommunication Union (ITU) Radio Regulations (RR), the International Convention on Maritime Search and Rescue, 1979, as amended, and the IAMSAR Manual.

2 In order to ensure uniformity of the ~~search-and-rescue~~SAR broadcast product throughout the world, C codes should be used as described in this part.

3 Shore-to-ship distress alert relays

3.1 As a general principle, distress alert relays should be addressed to a circular area around the estimated or known position of the distressed vessel. The radius of the circle should be chosen to take account of the accuracy of the datum position, the expected density of shipping in the vicinity and the fact that the position can only be defined in the message address to the nearest whole degree of latitude and longitude. The distress alert relay message must be broadcast via all satellites, which cover the area concerned. Shore-to-ship distress alert relays sent by the International SafetyNET Service should contain the identification of the unit in distress, its approximate position and other information, which might facilitate rescue. C codes should be as follows:

3.2 C₁ – Message priority

C ₁ = 3 (distress)

3.3 C₂ – Service code

C ₂ = 14 (shore-to-ship distress alert to circular areas)	Messages addressed to circular areas will only be received and printed out by EGC receivers that are located inside the circle or have not
---	--

	had their position kept up to date
--	------------------------------------

3.4 C₃ – Address code

<p>C₃ = ten alphanumeric characters D₁D₂LaD₃D₄D₅LoR₁R₂R₃</p>	<p>When C₂ = 14 for distress alert to user defined circular area, then:</p> <p>D₁D₂La (three characters) is latitude of vessel in distress in degrees (two digits) and whether north (N) or south (S): e.g., 39N (three characters total). A leading zero should be included for latitudes less than 10°</p> <p>D₃D₄D₅Lo (four characters) is longitude of vessel in distress in degrees (three digits) and whether east (E) or west (W) of the prime meridian: e.g., 059W. A leading zero or zeros should be included for longitudes less than 100° or 10° as appropriate: e.g., use 099 for 99° and 008 for 8°</p> <p>R₁R₂R₃ (three characters) is alert radius around distressed vessel in nautical miles. To ensure that position inaccuracies of both the distressed vessel and nearby vessels to which the message is intended do not affect receipt of messages, radius values of 200 nautical miles or larger should normally be used. Note that if a vessel's own position information is not entered into its SafetyNET receiver, every shore-to-ship distress alert relay message transmitted to the Inmarsat oOcean rRegion will be received and printed</p>
---	--

3.5 C₄ – Repetition code

<p>C₄ = 11</p>	<p>Use for distress alerts (transmit on receipt followed by repeat six min later)</p>
---------------------------	---

3.6 C₅ – Presentation code

C ₅ = 00	The code 00 for International Alphabet Number 5 is normally used
---------------------	--

4 General (all ships) call

4.1 When the RCC has no indication of the position of the vessel in distress, shore-to-ship distress alert relays may be sent as general call. This will be printed in every vessel within the Inmarsat **O**cean **R**egion, provided the receiver is tuned to the proper **O**cean **R**egion satellite.

Note: This method of alert should rarely be used.

The C₀:C₁:C₂:C₃:C₄:C₅ codes for general calls are always as follows:

- C₀ = 0 (1, 2 or 3) (if required)
- C₁ = 3 (distress) or 2 (urgency)
- C₂ = 00
- C₃ = 00
- C₄ = 11
- C₅ = 00

5 Search and **R**escue coordination traffic

5.1 ~~Search and rescue~~**SAR** coordination messages should be addressed to user defined circular or rectangular areas for the intent of coordinating the **S**earch and **r**escue of a vessel in distress. Priority of the message will be determined by the phase of the emergency.

5.2 C₁ – Message priority

C₁ = 3 (distress), 2 (urgency) or 1 (safety)

5.3 C₂ – Service code

C ₂ = 34	Search and R ₁ rescue coordination to a rectangular area
C ₂ = 44	Search and R ₁ rescue coordination to a circular area

5.4 C₃ – Address code

C ₃ = twelve alphanumeric characters D ₁ D ₂ LaD ₃ D ₄ D ₅ LoD ₆ D ₇ D ₈ D ₉ D ₁₀	When C ₂ = 34 S ₁ Search and R ₁ rescue coordination to a rectangular area Note: The definition of 12 characters for a rectangular address is given in part A, paragraph 5.3
C ₃ = ten alphanumeric characters D ₁ D ₂ LaD ₃ D ₄ D ₅ LoR ₁ R ₂ R ₃	When C ₂ = 44 S ₁ Search and R ₁ rescue coordination to a circular area Note: The definition of 10 characters for a circular address is given in part B, paragraph 3.3

5.5 C₄ – Repetition code

C ₄ = 11	Use for distress alerts (transmit on receipt followed by repeat six min later)
---------------------	--

5.6 C₅ – Presentation code

C ₅ = 00	The code 00 for International Alphabet Number 5 is normally used
---------------------	--

6 Shore-to-ship urgency and safety traffic

6.1 As a general principle, only the minimum information consistent with the safety of navigation should be broadcast. However, where such

information is deemed essential, shore-to-ship information other than distress alerts should be broadcast to a NAVAREA using C codes as follows:

6.2 C₁ – Message priority

C ₁ = 2 (urgency) or 1 (safety)
--

6.3 C₂ – Service code

C ₂ = 31

6.4 C₃ – Address code

C ₃ = two digits X ₁ X ₂

When C ₂ = 31, then:

X ₁ X ₂ are the two digits of the NAVAREA number (with a leading zero where necessary in the range 01–21)

6.5 C₄ – Repetition code

C ₄ = 11

Use for unscheduled broadcasts of urgency and safety traffic (transmit on receipt followed by repeat six min later)

6.6 C₅ – Presentation code

C ₅ = 00

The code 00 for International Alphabet Number 5 is normally used
--

7 SAR broadcast for overlapping satellite Ocean Regions

7.1 Search and Rescue distress and urgency broadcasts should be

promulgated through all Inmarsat satellites serving the area surrounding the vessel in distress. This is to ensure that vessels with receivers tuned to any Ocean-FRegion satellite serving the area will receive the message.

Part D – Piracy countermeasures broadcast messages

Format: n (Body_text)

1 On receiving a message of alert or any other information concerning a threat of attack (from the Security Forces Authority responsible for the operational application of the urgency plans (countermeasures) in the region or another MRCC, for example), the MRCC should ask the NAVAREA coordinator (or any other competent authority in accordance with local arrangements), to send out a warning through the appropriate MSI network (NAVTEX or SafetyNET) and other broadcasting networks for warnings to shipping, if these exist.

2 There are two kinds of MSI broadcast messages associated with piracy countermeasures: the daily situation report (SITREP) and a piracy attack warning. Specific guidance on drafting and broadcasting these messages is given below.

3 The daily situation report should be broadcast via SafetyNET at a regular time around 0800 local time daily. The following paragraphs provide specific guidance on broadcast procedures.

4 The daily situation report should be broadcast to a rectangular area enclosing the region of probable piracy attacks (based on historical data) plus a margin of 700 nautical miles (24 hours steaming by a fast ship) in every direction.

5 The following C codes illustrate those to be used for SafetyNET broadcasts of the daily SITREP:

5.1 C₁ – Message priority

C ₁ = 1 (safety)

5.2 C₂ – Service code

C ₂ = 04	SITREP to a rectangular area
C ₂ = 24	SITREP to a circular area

5.3 C₃ – Address code

C ₃ = twelve alphanumeric characters D ₁ D ₂ LaD ₃ D ₄ D ₅ LoD ₆ D ₇ D ₈ D ₉ D ₁₀	When C ₂ = 04 SITREP to a rectangular area Note: The definition of 12 characters for a rectangular address is given in part A, paragraph 5.3
C ₃ = ten alphanumeric characters D ₁ D ₂ LaD ₃ D ₄ D ₅ LoR ₁ R ₂ R ₃	When C ₂ = 24 SITREP to a circular area Note: The definition of 10 characters for a circular address is given in part B, paragraph 3.3

5.4 C₄ – Repetition code

C ₄ = 18	Broadcast every 24 hours (no echo) until cancelled
---------------------	--

5.5 C₅ – Presentation code

C ₅ = 00	The code 00 for International Alphabet Number 5 is normally used
---------------------	--

6 A piracy attack warning shall be broadcast as an "URGENT" NAVAREA or coastal warning immediately on receipt of the source information and at least at the next scheduled broadcast or for as long as the information remains valid. In the area of overlap coverage from two or three Ocean Region satellites, urgent warnings will be broadcast over all satellites₁ which cover the affected region. Subject indicator character B₂ = L should be used in coastal warning areas. The specific area in

which the attack has taken place is to be quoted in the first line of the text, using no more detail than is necessary to indicate the probable location of further attacks, e.g., WESTERN PHILIP CHANNEL or VICINITY HORSBURGH LIGHT. The description of the pirate vessel and its last observed movements are to be kept as brief as possible and should give only those details which are of significance in avoiding other attacks.

7 The following C codes illustrate those to be used for SafetyNET broadcast of piracy attack warnings:

7.1 C₁ – Message priority

C ₁ = 2 (urgency)

7.2 C₂ – Service code

C ₂ = 13	Coastal warning
C ₂ = 31	NAVAREA warning

7.3 C₃ – Address code

C ₃ = two digits X ₁ X ₂	When C ₂ = 31 then: X ₁ X ₂ are the two digits of the NAVAREA number (with a leading zero where necessary in the range 01 to 21)
C ₃ = four alphanumeric characters X ₁ X ₂ B ₁ B ₂	When C ₂ = 13 for coastal warnings then: X ₁ X ₂ are the two digits of the NAVAREA number (with a leading zero where necessary in the range 01 to 21) B ₁ is the coastal warning area A to Z B ₂ is the subject indicator and must always be A or L, where: A = Navigational warnings L = Other navigational warnings

7.4 C₄ – Repetition code

C ₄ = 16	Broadcast every 12hours with no echo until cancelled
---------------------	--

7.5 C₅ – Presentation code

C ₅ = 00	The code 00 for International Alphabet Number 5 is normally used
---------------------	--

8 Date/time should always be quoted in the form:

DDHHMM UTC MoMoMo YY

as in the example: 251256 UTC JUN 12

Note: UTC (Coordinated Universal Time) is the same time-zone as GMT (Z).

9 Geographical positions should be quoted in the standard format:

D₁D₂M₁M₂LaD₃D₄D₅M₃M₄Lo

where:

D₁D₂ = degrees latitude (with leading zero if required)

M₁M₂ = minutes latitude

La = hemisphere (N or S)

D₃D₄D₅ = degrees longitude (with leading zeros if required)

M₃M₄ = minutes longitude

Lo = longitude (E or W)

as in the example: 5419N10327E

Notes:

1. Examples of format and drafting guidance for piracy warnings is contained in the *Joint IMO/IHO/WMO Manual on Maritime Safety Information* (MSC.1/Circ.1310, as amended, and IHO Publication No. S-53).

2. Decimals of minutes will seldom be necessary or appropriate for reports of this kind.

3. Where the name of a geographical feature is used instead of a geographical position, a name should be chosen that appears on all commonly used charts of the area. Local knowledge should not be required for understanding the message.

Part E – Repetition codes (C₄)

Formatert: Engelsk (Storbritannia)

1 The C₄ repetition codes are divided into two categories:

Category (a) for messages that are required to be repeated a finite number of times; and

Category (b) for messages that are required to be repeated at specified intervals until cancelled by the MSI provider.

1.1 Category (a) repetition codes:

Code	Instruction
01	transmit once on receipt
11	transmit on receipt followed by repeat six min later
61	transmit on receipt and 1 hour after initial broadcast (twice)
62	transmit on receipt and 2 hours after initial broadcast (twice)
63	transmit on receipt and 3 hours after initial broadcast (twice)
64	transmit on receipt and 4 hours after initial broadcast (twice)
66	transmit on receipt and 12 hours after initial broadcast (twice)
67	transmit on receipt and 24 hours after initial broadcast (twice)
70	transmit on receipt, 12 hours after initial broadcast and then 12 hours

	after the second broadcast (three times)
71	transmit on receipt, 24 hours after initial broadcast and then 24 hours after the second broadcast (three times)

1.2 Category (b) repetition codes:

A category (b) repetition code allows a message to be repeated indefinitely or until cancelled by the message provider. The repetition period can be set at between 1 and 120 hours. In addition, each transmission can be echoed after a fixed period of six minutes. Repetition codes are made up by stating the multiplier first, followed by the delay period:

Multiplier x Delay

where the multiplier specifies the amount of delay periods between each broadcast, and the delay is a fixed number of hours. The **multiplier** digit may be any digit from 1 to 5 as follows:

- 1 = 1 specified delay period between broadcasts
- 2 = 2 specified delay periods between broadcasts
- 3 = 3 specified delay periods between broadcasts
- 4 = 4 specified delay periods between broadcasts
- 5 = 5 specified delay periods between broadcasts

The delay digit coding is as follows:

- 2 = 1 hour delay; no echo
- 3 = 1 hour delay; with echo
- 4 = 6 hours delay; no echo
- 5 = 6 hours delay; with echo
- 6 = 12 hours delay; no echo
- 7 = 12 hours delay; with echo
- 8 = 24 hours delay; no echo
- 9 = 24 hours delay; with echo

Formatert: Engelsk (Storbritannia)

The various combinations (Multiplier x Delay) available, are shown in the table below:

Code	Instruction
12	repeat broadcast every 1 hour with no echo
13	repeat broadcast every 1 hour with an echo six minutes after each broadcast
22	repeat broadcast every 2 hours with no echo
23	repeat broadcast every 2 hours with an echo six minutes after each broadcast
32	repeat broadcast every 3 hours with no echo
33	repeat broadcast every 3 hours with an echo six minutes after each broadcast
42	repeat broadcast every 4 hours with no echo
43	repeat broadcast every 4 hours with an echo six minutes after each broadcast
52	repeat broadcast every 5 hours with no echo
53	repeat broadcast every 5 hours with an echo six minutes after each broadcast

Code	Instruction
14	repeat broadcast every 6 hours with no echo
15	repeat broadcast every 6 hours with an echo six minutes after each broadcast
16 (or 24)	repeat broadcast every 12 hours with no echo
17 (or 25)	repeat broadcast every 12 hours with an echo six minutes after each broadcast
34	repeat broadcast every 18 hours with no echo
35	repeat broadcast every 18 hours with an echo six minutes after each broadcast
18 (or 26; or 44)	repeat broadcast every 24 hours with no echo
19 (or 27; or 45)	repeat broadcast every 24 hours with an echo six minutes after each broadcast
54	repeat broadcast every 30 hours with no echo
55	repeat broadcast every 30 hours with an echo six minutes after each broadcast
36	repeat broadcast every 36 hours with no echo
37	repeat broadcast every 36 hours with an echo six minutes after each broadcast
28 (or 46)	repeat broadcast every 48 hours with no echo

Code	Instruction
29 (or 47)	repeat broadcast every 48 hours with an echo six minutes after each broadcast
56	repeat broadcast every 60 hours with no echo
57	repeat broadcast every 60 hours with an echo six minutes after each broadcast
38	repeat broadcast every 72 hours with no echo
39	repeat broadcast every 72 hours with an echo six minutes after each broadcast
48	repeat broadcast every 96 hours with no echo
49	repeat broadcast every 96 hours with an echo six minutes after each broadcast
58	repeat broadcast every 120 hours with no echo
59	repeat broadcast every 120 hours with an echo six minutes after each broadcast

Note: Not all codes may be provided by all service providers.

Annex 5

EGC receiver specifications - Inmarsat C and Mini C

These technical requirements were defined by Inmarsat for equipment manufacturers and have been extracted from the System Definition Manual (SDM) for the Inmarsat C communications system.

~~Enhanced Group Call~~ (EGC) receive facilities are used by SOLAS Convention ships as well as ships not required to comply with the requirements of the SOLAS Convention, as amended. It should be noted that EGC receive facilities intended to meet SOLAS Convention requirements must comply with the IMO Recommendation on Performance Standards for Enhanced Group Call Equipment contained in resolution A.664(16), as amended and the Amendments to the Revised Performance Standards for Enhanced Group Call (EGC) equipment in resolution MSC.431(98), d.

The specific guidance given in this annex has been carefully coordinated to ensure that the automatic functions of the SafetyNET receivers work properly. Land Earth Stations providing Inmarsat C services for the GMDSS must comply with all relevant aspects of the Inmarsat C Service Description Manual (SDM), including provision of the EGC SafetyNET services.

Technical requirements for Enhanced Group Call receivers for SOLAS-compliant MESS

1 EGC SafetyNET receivers for SOLAS installations

1.1 Background

The Global Maritime Distress and Safety System (GMDSS) is a radiocommunication system based on satellite and terrestrial technology, designed to improve communications relating to distress and safety of life at sea. It was adopted by the International Maritime Organization (IMO) in 1988, in the form of Amendments to the International Convention for the Safety of Life at Sea (SOLAS), 1974 and came into effect on 1 February 1992. Implementation was completed on 1 February 1999.

Formatert: Uttheving

Formatert: Uttheving

Formatert: Uttheving

Formatert: Uttheving

Formatert: Uttheving

It is the responsibility of national Administrations to determine whether a radio installation on board a ship meets the SOLAS requirements. This is done by national Type Acceptance or Approval testing of the sub-systems included in the installation and by inspection of the complete installation by a radio surveyor.

National Type Acceptance testing for SOLAS equipment is usually based on GMDSS specifications and procedures prepared by IMO and the International Electrotechnical Commission (IEC) on their behalf, although other national or regional specifications may be invoked as well.

IMO and IEC documents, which are identified in section 1.2, do not only summarize the general requirements for GMDSS equipment, but also the special requirements for EGC SafetyNET receivers for use in SOLAS installations, as specified by IMO/IEC.

A number of the Inmarsat specifications have been completely revised to reflect the latest IMO/IEC requirements, for example, electromagnetic compatibility and environmental requirements.

1.2 Principal relevant documents

For Inmarsat C and ~~m~~Mini-C GMDSS compliant MESs with EGC SafetyNET function, the principal relevant documents in addition to the Inmarsat C SDM are:

- .1 Performance Standards for Enhanced Group Call Equipment – Annex: Recommendation on Performance Standards for Enhanced Group Call Equipment, published by IMO as resolution A.664(16), as amended.
- .2 Amendments to the Revised Performance Standards for Enhanced Group Call (EGC) equipment, published by IMO as resolution MSC.431(98), as amended.
- .3 General Requirements for Shipborne Radio Equipment Forming Part of the Global Maritime Distress and Safety System (GMDSS) and for Electronic Navigational Aids, published by IMO as resolution A.694(17).
- .43 Performance Standards for Inmarsat ~~Standard-C~~ Ship Earth

Stations Capable of Transmitting and Receiving Direct-printing Communications – Annex: Recommendation on Performance Standards for Inmarsat Standard-C Ship Earth Stations Capable of Transmitting and Receiving Direct-printing Communications, published by IMO as resolution A.807(19), as amended by resolution MSC.68(68), Annex 4.

- .54 [Performance standards for a Ship Earth Station for use in the GMDSS, published by IMI as resolution MSC.434\(98\), as amended.](#)
- .6 Shipborne Radio Equipment Forming Part of the Global Maritime Distress and Safety System and Marine Navigational Equipment, published by the IEC as IEC 60945.
- .67 Global Maritime Distress and Safety System (GMDSS) – Part 4: Inmarsat C Ship Earth Station and Inmarsat Enhanced Group Call (EGC) Equipment – Operational and Performance Requirements, Methods of Testing and Required Test Results, published by the IEC as IEC 61097-4.
- .86 Maritime Design and Installation Guidelines (DIGs), Annex B, issue 6 of April 2008 published by Inmarsat at:
<http://www.inmarsat.com/Maritimesafety/DIGs.pdf>

2 Introduction

2.1 Enhanced Group Calls

Enhanced Group Calls are a message broadcast service transmitted over the Inmarsat C communications system. The service allows terrestrial information providers to pass messages or data to Class 2 or Class 3 MESs with EGC receivers or Class 0 stand-alone EGC receivers through the Inmarsat C LESs. The messages are processed at the addressed LES and forwarded to the NCS, which transmits them on the common channel.

2.2 EGC receiver

An EGC receiver is defined as a single-channel receiver with a dedicated message processor. Mobile Earth Stations of Class 2 and 3 provide an EGC capability in addition to To-Ship and From-Ship

messaging capabilities; class 0 MESSs are self-contained EGC receivers as shown in [Figure 9](#).

Note: Most of the existing models of Inmarsat C and [mMini_C](#) maritime terminals on the market are Class 2 MESSs.

2.3 Type approval

The Inmarsat C SDM presents the technical requirements and recommendations for an EGC receiver. These requirements must be satisfied before the equipment can be utilized in the Inmarsat system. Procedures for type approval by Inmarsat of a manufacturer's design are provided in a complementary document entitled Type Approval Procedures for Inmarsat C and [mMini_C](#) Ship Earth Stations published by Inmarsat.

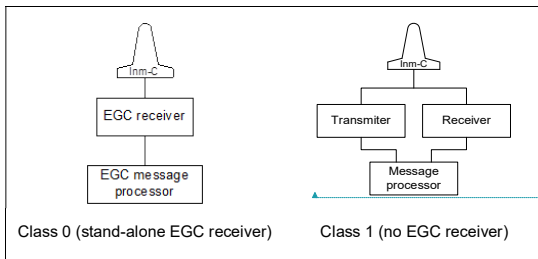

Feltkode endret

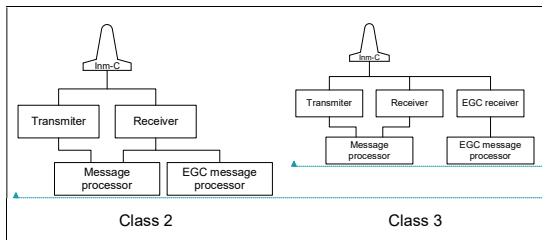

Feltkode endret
Feltkode endret

Figure 10,- Classes of Inmarsat C Mobile Earth Stations

3 General requirements

3.1 Mandatory capabilities

The mandatory capabilities of SafetyNET receivers for SOLAS applications are:

- .1 continuous reception of an NCS common channel and processing of the information according to the EGC message protocol; a Class 2 Inmarsat C MES continuously receives the NCS common channel when not engaged in general communications;
- .2 automatic recognition of messages directed to fixed and absolute geographical areas and service codes as selected by the receiver operator or based upon input(s) from navigational equipment;
- .3 SafetyNET receivers meet the requirements of IEC 61097-4 and IEC 60945; and
- .4 where automatic updates are not available, provision is made for a visual indication if the ship's position has not been updated during the last 12 hours. It is only possible to reset

this indication by revalidating the ship's position.

4 NCS common channel selection

4.1 General

EGC receivers are equipped with facilities for storing up to 20 NCS channel numbers. Four of these are permanently assigned global beam channel numbers and frequencies as follows:

NCS	NSC common channel	
	Channel No.	Frequency
AOR-West	11080	1537.70 MHz
AOR-East	12580	1541.45 MHz
POR	12580	1541.45 MHz
IOR	10840	1537.10 MHz

These four channel numbers are stored in ROM and are not alterable.

4.2 NCS scanning

Automatic NCS scanning on a regular basis is prohibited in SOLAS SafetyNET receivers. In the event of low signal strength from the satellite, an alarm is raised and the operator is advised to initiate NCS scanning manually.

5 Message-processing requirements

5.1 General

Acceptance or rejection of the EGC service code types is under operator control except that receivers always receive navigational warnings, meteorological warnings, SAR information and To-Ships distress alerts which are directed to a fixed or absolute geographical area within which the receiver is situated.

5.2 Display devices

5.2.1 Message display

The display is capable of presenting at least 40 characters per line of text. The EGC receiver ensures that if a word cannot be accommodated in full on one line it is transferred to the next line.

5.2.2 Status display

An indication of EGC carrier frame synchronization (or loss of synchronization) is provided.

5.3 Printer requirements

A printer is required for a SOLAS SafetyNET receiver. Received EGC messages may be stored for later printing with an indication to the operator that the message has been received. However, distress or urgency priority calls are directly printed as well as stored. Means are also provided not to print or store the same EGC message after it has been received error-free and printed.

Messages are not printed until completely received.

A local audible alarm is sounded to give advance warning of a printer "paper-low" condition.

All SafetyNET messages are annotated with the date and time (UTC) of reception. This information is displayed or printed with the message.

5.4 Character codes

For the EGC service, the International Reference Version of the International Alphabet 5 (IA5), also known as ASCII (a standard alphanumerical character set based on 7-bit codes) is used.

5.5 Operator control

The following control functions and displays are provided as a minimum:

- .1 selection of EGC carrier frequency;

For SOLAS SafetyNET receivers:

- .2 means of inputting the following information:
 - .1 MES's position coordinates;
 - .2 current and planned (additional) NAVAREA(s)/METAREA(s);
 - .3 current and planned coastal warning area (B₁ Code); and
 - .4 coastal warning subject indicator character (B₂ Code).

Receivers are fitted with operator controls to allow the operator to select desired geographical areas and message categories. Details of the geographical areas and message categories, which have been selected for reception by the operator are readily available.

5.6 EGC receiver memory capacity requirements

Both temporary and non-volatile memory is required in an EGC receiver for the following purposes:

- .1 message buffering;
- .2 maintaining message identification records;
- .3 storing position coordinates and NAVAREA(s)/METAREA(s) data; and
- .4 storing expansion of NCS common channel numbers.

5.7 EGC receiver addressing

The five basic methods of addressing MSI receivers are:

- .1 All-mobiles call (Inmarsat only);
- .2 Inmarsat system message addressing (Inmarsat only);
- .3 Fixed geographical area (NAV/METAREA);
- .4 Temporary area determined by MSI provider - circular or rectangular; _____
- .5 Coastal warning area;

The type of address used in the header of an MSI packet is uniquely determined by the "C₂" service code field.

The five basic methods of addressing EGC receivers are:

- .1 all-mobiles call;
- .2 Inmarsat system message addressing;
- .3 group addressing;
- .4 unique addressing; and
- .5 geographical area addressing including coastal addressing.

The type of address used in the header of an EGC packet is uniquely determined by the "C₂" service code field.

5.8 Message identification

All messages are transmitted with a unique sequence number, originating LES ID and service code. Each subsequent transmission of the message contains the original sequence number. This facility allows multiple printing of repeated messages to be inhibited.

5.9 Geographical area addressing

Geographical area addressing refers to messages transmitted to MESS in a particular area. The area may be expressed in terms of a fixed, pre-defined area such as the NAVAREA/METAREA, or satellite coastal warning area, or in terms of an absolute geographical address expressed as latitude and longitude coordinates on the surface of the earth. An absolute geographical area address is a representation of a closed boundary on the surface of the earth given in the address field of

the message header. The receiver recognizes two forms of absolute geographical addressing: rectangular and circular. Each form is specified in terms of an absolute position in latitude and longitude and further parameters that completely specify the boundary.

In order to process a geographical area address, the receiver shall be programmed with the MES's current position. The position may be entered automatically from an integrated or external navigation aid or entered manually. The receiver provides notification to the operator when the position has not been updated for four hours. If the MES's position has not been updated for more than 12 h, or is unknown, **ALL** SafetyNET messages will be printed or stored in memory.

A geographical area address is considered valid for a particular MES if its current position falls inside or on the boundary specified by the address. It is a mandatory requirement that the operator be able to select more than one area, so that messages directed to other area(s) of interest can be provided. It is recommended that the operator be able to select at least four areas.

6 Link performance monitoring

The SafetyNET EGC receiver continuously monitors the received bulletin board error rate (BBER) as a measure of link performance whenever it is tuned and synchronized to a NCS (or LES) time division multiplex (TDM). The receiver stores a count of the number of bulletin boards received in error out of the last 100 received. This count is continuously updated frame by frame.

7 Alarms and indications

The following alarms and indications are provided at a SOLAS SafetyNET receiver and meet the operational requirements for alarms stated in IEC 61097-4.

7.1 Distress/Urgency priority call alarm

For SOLAS SafetyNET receivers:

Provision is made for a specific audible alarm and visual indication at the position from which the ship is normally navigated to indicate receipt of SafetyNET messages with distress or urgency priority. It is not possible to disable this alarm and it is only possible to re-set it manually, and then only from the position where the message is displayed or printed.

7.2 Other alarms and indications

- .1 high BBER;
- .2 printer paper low;
- .3 receiver fault indication;
- .4 loss of receiver synchronization; and
- .5 position update.

Additional alarms and indications may be provided at the manufacturer's discretion.

8 Electromagnetic compatibility

The interference and electromagnetic compatibility requirements of IEC 60945 applies.

9 Environmental conditions

SOLAS SafetyNET receivers shall operate satisfactorily under the environmental conditions specified in the SDM. The latest issues of IEC 61097-4 and IEC 60945 apply.

10 Navigational interface

In order that a receiver's position may be automatically updated, receivers may be equipped with an interface to navigational instruments. A suggested standard interface is in IEC 61162, Part 1 (NMEA 0183) Standard for Interfacing Electronic Marine Navigational Devices.

Note: The majority of modern maritime MESs have an integrated navigational receiver.

Annex 6

SafetyNET II

Kommentert [ST38]: WWNWS10, end of review.

Formatert: Utheving

Formatert: Utheving

-

1 Introduction of SafetyNET II

1.1 SafetyNET II provides shipping with navigational and meteorological warnings, meteorological forecasts, shore-to-ship distress alerts, SAR information and other urgent information in accordance with the requirements of the International Convention for the Safety of Life at Sea (SOLAS), 1974, as amended. It is suitable for use in all sizes and types of ships.

Formatert: Blokkjustert, Linjeavstand: Enkel

Formatert: Skrift: 11 pkt, Fet, Ikke Kursiv

Formatert: Skrift: 9,5 pkt, Ikke Kursiv

Formatert: Skrift: 9,5 pkt, Ikke Kursiv, Utheving

Formatert: Blokkjustert, Mellomrom Før: 0 pkt., Linjeavstand: Enkel

Formatert: Skrift: 9,5 pkt, Ikke Kursiv

Formatert: Skrift: 9,5 pkt, Ikke Kursiv

1.2 SafetyNET II is an enhancement to the current SafetyNET system. SafetyNET II provides an interactive web portal or application programming interface (API) for information providers to create their MSI messages and deliver them over the Inmarsat EGC system interactive web interface for MSIPs to create their MSI messages and deliver them

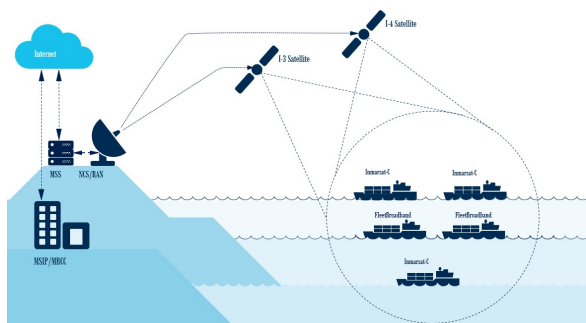

over multiple systems simultaneously, including Inmarsat C, Mini C, and Fleet Safety as illustrated by Figure 11.

Figure 11 - Overview SafetyNET II

1.3 SafetyNET II offers a secure web interface. The MSIP is issued a personal login to the Maritime Safety Server (MSS) that will store on the MSS database a record of all messages sent. Once the MSS receives an MSI from the MSIP, it will route the message to the Inmarsat C Network Coordination Station (NCS) and to the Broadband Global Area Network Satellite Access Station (BGAN SAS) for transmission over the I-4 network.

Kommentert [ST39]: WVNWS10, Dana to remove MRCC.

Formatert: Kontroller staving og grammatikk

Formatert: Skrift: 9,5 pkt, Ikke Kursiv

Formatert: Skrift: 9,5 pkt, Ikke Kursiv

Formatert: Skrift: 9,5 pkt

Kommentert [ST40]: WVNWS10.

Formatert: Skrift: 9,5 pkt

Formatert: Skrift: 9,5 pkt

Formatert: Skrift: 9,5 pkt

Formatert: Skrift: 9,5 pkt, Ikke Kursiv

Formatert: Skrift: 9,5 pkt, Ikke Kursiv

Formatert: Skrift: 9,5 pkt, Ikke Kursiv

Formatert: Skrift: 9,5 pkt, Ikke Kursiv

Formatert: Skrift: 9,5 pkt

Formatert: Skrift: 9,5 pkt

Formatert: Mellomrom Før: 0 pkt., Linjeavstand: Enkel

Formatert: Skrift: 9,5 pkt, Ikke Kursiv

Formatert: Blokkjustert, Linjeavstand: Enkel

Formatert: Skrift: 9,5 pkt, Ikke Kursiv

Formatert: Skrift: 9,5 pkt, Ikke Kursiv

1.4 SafetyNET II offers MSIPs the ability to direct a message to a given geographical area. The area may be fixed, as in the case of a NAVAREA/METAREA or coastal warning area; or it may be a user-defined area (circular or rectangular). A user-defined area is used for messages, such as a local storm warning or a shore-to-ship distress alert, for which it is inappropriate to alert ships in an entire satellite Ocean Region or NAVAREA/METAREA.

Formatert: Skrift: 9,5 pkt, Ikke Kursiv

Formatert: Skrift: 9,5 pkt, Ikke Kursiv

Formatert: Skrift: 9,5 pkt, Ikke Kursiv

Formatert: Skrift: 9,5 pkt, Ikke Kursiv

2 SafetyNET II service overview

Formatert: Skrift: 11 pkt, Fet, Ikke Kursiv

2.1 The Maritime Safety Server (MSS) is the core of SafetyNET II. The MSS is owned and operated by Inmarsat as part of its commitment to maritime safety services and its public service agreement obligations. The MSS interfaces between the shore-based maritime safety infrastructure, e.g. MSIPs, and the seafarer, who uses a Maritime Safety Terminal (MST), via the FleetBroadband system. Additionally the MSS provides interconnectivity to the Inmarsat C system for the purposes of sending and receiving Maritime Safety Information (MSI). The MSS offers high resilience through internal application redundancy and geographical redundancy as illustrated by Figure 12.

Formatert: Skrift: 9,5 pkt, Ikke Kursiv

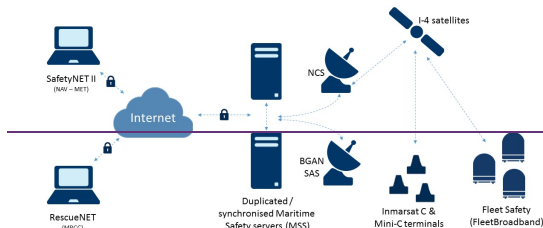

Figure 12 - Overview SafetyNET II

Formatert: Blokkjustert, Linjeavstand: Enkel

2.2 The MSIP is responsible for providing reliable communication links to the system's network for efficient handling of shore-to-ship distress alert relays and distress traffic, preferably via dedicated communication links (A.1001(25)).

Formatert: Skrift: 9,5 pkt, Ikke Kursiv

2.3 SafetyNET II can broadcast MSI to Fleet Safety users through the Radio Access Network (RAN), and to Inmarsat C users through the Network Coordination Station (NCS). The MSI and all scheduling information are stored in the MSS database. The MSS uses a scheduler component to schedule the MSI promulgation. The scheduler will schedule:

- Each MSI according to the MSI start/end time and repetition scheme.
- MSI transmission for individual spots handling 6 minutes echo and temporary transmission problems.

Formatert: Blokkjustert, Mellomrom Før: 0 pkt., Etter: 0 pkt., Linjeavstand: Enkel, Punktmerket + Nivå: 1 + Justert ved: 0,63 cm + Innrykk ved: 1,27 cm

2.4 In Inmarsat C, MSI are broadcast using the Inmarsat C Enhanced Group Call (EGC) service and conform to GMDSS conventions described in the IMO SafetyNET Manual. They are characterised by five 'C codes': Priority, Service, Address, Repetition and Presentation.

Formatert: Blokkjustert, Linjeavstand: Enkel

Formatert: Skrift: 9,5 pkt, Ikke Kursiv

2.5 MSI will be broadcasted to Inmarsat C, Mini C and Fleet Safety terminals.

Formatert: Skrift: 9,5 pkt, Ikke Kursiv

3 Operation of the SafetyNET II services

Formatert: Skrift: 11 pkt, Fet, Ikke Kursiv

Formatert: Skrift: 11 pkt, Fet, Ikke Kursiv

3.1 The MSS supports MSI promulgation. The basic design for MSDS MSI is based on the Inmarsat C EGC and the derived SafetyNET service. The MSI is stored on the MSS for broadcast to User Terminal (UT) on Inmarsat C or FleetBroadband satellite networks.

Formatert: Skrift: 9,5 pkt, Ikke Kursiv

Formatert: Skrift: 9,5 pkt, Ikke Kursiv

3.2 The MSI is stored with the following information:

<u>Name</u>	<u>Value</u>	<u>Comment</u>
<u>C0</u>	<u>Satellite Ocean Region</u>	<u>Inmarsat C and Fleet Safety specific</u>
<u>C1</u>	<u>Priority</u>	<u>Urgency or Safety</u>
<u>C2</u>	<u>Service code</u>	<u>See 3.6</u>
<u>C3</u>	<u>MSI address</u>	<u>See 3.7</u>
<u>C4</u>	<u>Repetition scheme</u>	<u>See 3.8</u>
<u>C5</u>	<u>Presentation</u>	<u>MSIv1 supports IA5 (7bit) and 8-bit transparent data</u>
<u>Pay-load</u>	<u>Data</u>	<u>Max 64kbit payload for BGAN</u> <u>Max 32kbit payload for Inmarsat C</u>

3.3 The MSS determines the satellite spots covering the MSI area, and broadcasts the MSI in these spots. MSI is received by the user terminals (UTs) listening at the time of the broadcast. The basic MSI broadcast scheme does not guarantee delivery to all UTs within the MSI area. A UT can be temporarily unavailable (e.g. spot handover), and may not receive the MSI broadcast.

Formatert: Skrift: 9,5 pkt, Ikke Kursiv

Formatert: Skrift: 9,5 pkt, Ikke Kursiv

Formatert: Skrift: 9,5 pkt, Ikke Kursiv

Formatert: Blokkjustert, Linjeavstand: Enkel

3.4 A repetition scheme is defined for the MSI, causing the MSS to repeat the MSI periodically. The repetition scheme increases the likelihood that all UTs within the MSI area will eventually have received the MSI. Repeating the MSI is also used to reach UTs entering the MSI area. The UT can be outside the area at the time of the first broadcast, but within the area for the next.

3.5 The MSS maintains a configurable table of supported MSI service codes. The table contains the service codes supported for Inmarsat C SafetyNET, but can be extended with additional service codes specific to FleetBroadband.

Formatert: Skrift: 9,5 pkt, Ikke Kursiv

3.6 A table is used internally by the MSS to map between the different C2 service codes supported on FleetBroadband and Inmarsat C. The table is used by the MSS Graphical User Interface to present allowed C code options specific to a selected C2 service code.

Formatert: Skrift: 9,5 pkt, Ikke Kursiv

Formatert: Skrift: 9,5 pkt, Ikke Kursiv

3.7 The MSI can be addressed for broadcast in the following area types:

- All ships (in a specified Ocean Region)
- Circular Area
- Rectangular Area
- NAVAREA/METAREA
- Coastal Area (within NAVAREA/METAREA)
- Subarea (within NAVAREA/METAREA)
- Fixed Area

Formatert: Blokkjustert, Mellomrom Før: 0 pkt., Etter: 0 pkt., Linjeavstand: Enkel, Punktmerket + Nivå: 1 + Justert ved: 0,63 cm + Innrykk ved: 1,27 cm

Formatert: Skrift: 9,5 pkt, Ikke Kursiv

3.8 The MSS will support a repetition scheme controlled by the MSI C4 parameter. The scheme is based on the Inmarsat C EGC repetition schemes. Two schemes are supported for SafetyNET II and System EGCs:

- Category A (i.e. 1 or 2 transmissions)
- Category B (i.e. forever until MSI end time expires)

4 Message formatting in SafetyNET II

4.1 SafetyNET II offers a standard web application that provides a secure portal to MSIPs via public internet. All access will require secure login, which will be provided to the MSIP by the Inmarsat customer on-boarding team.

Formatert: Blokkjustert, Linjeavstand: Enkel

Formatert: Skrift: 9,5 pkt, Ikke Kursiv

Formatert: Blokkjustert, Mellomrom Før: 0 pkt., Linjeavstand: Enkel, Punktmerket + Nivå: 1 + Justert ved: 0,63 cm + Innrykk ved: 1,27 cm

Formatert: Skrift: 11 pkt, Fet, Ikke Kursiv

Formatert: Blokkjustert, Linjeavstand: Enkel

Formatert: Skrift: 9,5 pkt, Ikke Kursiv

Formatert: Kontroller staving og grammatikk

Formatert: Innrykk: Venstre: -1,25 cm, Linjeavstand: Enkel

Formatert: Skrift: 9,5 pkt

Formatert: Skrift: 9,5 pkt

Formatert: Skrift: 9,5 pkt, Ikke Kursiv

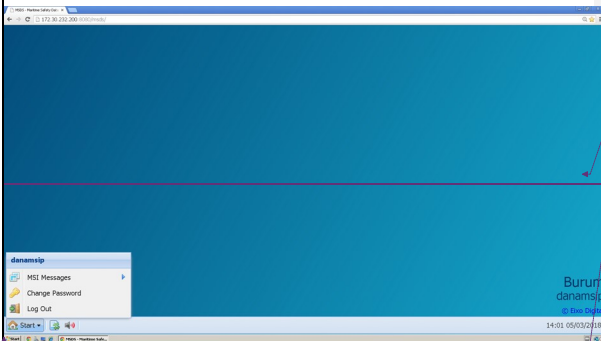

Figure 13.- SafetyNET II web application

4.2 The MSIP is responsible for using a standard, secure and up-to-date web browsers, such as Google Chrome or Mozilla Firefox.

Formatert: Skrift: 9,5 pkt, Ikke Kursiv

Formatert: Skrift: 9,5 pkt, Ikke Kursiv

Formatert: Blokkjustert, Linjeavstand: Enkel

4.3 As illustrated in Figure 12, after logging into the SafetyNET II portal, the MSIP has the option to create an MSI message under "MSI Messages". By clicking on "New MSI Message", the MSIP will be able to create an MSI through 7 steps.

Formatert: Skrift: 9,5 pkt, Ikke Kursiv

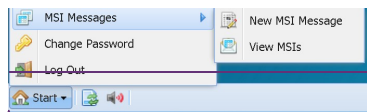

Formatert: Kontroller staving og grammatikk

Formatert: Linjeavstand: Enkel

Figure 14.- Start Menu

Formatert: Skrift: 9,5 pkt

Formatert: Mellomrom Før: 0 pkt., Linjeavstand: Enkel

Formatert: Skrift: 9,5 pkt

Formatert: Skrift: 9,5 pkt

4.4 Step 1 MSI Type

Formatert: Skrift: 9,5 pkt, Ikke Kursiv

Formatert: Blokkjustert, Linjeavstand: Enkel

4.4.1 In step 1 the MSIP can select the MSI Message Type, either "Navigational" or "Meteorological". The MSIP may only have access to one service type message format depending on MSIP authorisation, i.e. a NAVAREA coordinator will only have access to Navigational MSI types and a METAREA coordinator will have access to Meteorological MSI types.

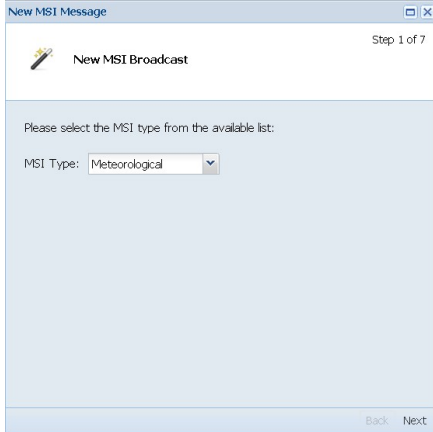

Figure 15 - Select MSI Type

Formatert: Kontroller staving og grammatikk

Formatert: Blokkjustert, Mellomrom Før: 0 pkt., Linjeavstand: Enkel

Formatert: Skrift: 9,5 pkt

Formatert: Mellomrom Før: 0 pkt., Linjeavstand: Enkel

Formatert: Skrift: 9,5 pkt

Formatert: Skrift: Kursiv

4.5 Step 2 Service Code

Formatert: Skrift: 9,5 pkt, Ikke Kursiv

Formatert: Blokkjustert, Linjeavstand: Enkel

4.5.1 Figure 15 illustrates step 2 in which a NAVAREA Coordinator can select the relevant NAVAREA service codes (i.e. 13-Coastal warnings, 51-Navarea warnings, 52-Navigational warnings, 53-International Ice patrol warnings, and 54-Piracy and Armed robbery warnings).

Figure 16 – Select NAV Service Code

New MSI Message

Step 2 of 7

New MSI Broadcast

Please select the Service Code from the available list:

Service Code: 13 - Coastal warnings

- 13 - Coastal warnings
- 51 - NAVAREA warnings
- 52 - Navigational warnings
- 53 - International Ice patrol warnings
- 54 - Piracy and Armed robbery warnings
- 55 - Tsunami warnings

Back Next

Formatert: Skrift: 9,5 pkt, Ikke Kursiv

Formatert: Skrift: Kursiv, Kontroller staving og grammatikk

Formatert: Skrift: 9,5 pkt, Ikke Kursiv

Formatert: Skrift: 9,5 pkt, Ikke Kursiv

Formatert: Skrift: 9,5 pkt, Ikke Kursiv

4.5.2 Figure 6 shows step 2 which a METAREA Coordinator can select the relevant METAREA service codes (i.e. 13-Coastal warnings, 61-METAREA warnings, 62-Meteorological warnings, and 63-Storm and Tropical warnings)

Formatert: Skrift: 9,5 pkt, Ikke Kursiv

Formatert: Blokkjustert, Linjeavstand: Enkel

Formatert: Skrift: 9,5 pkt, Ikke Kursiv

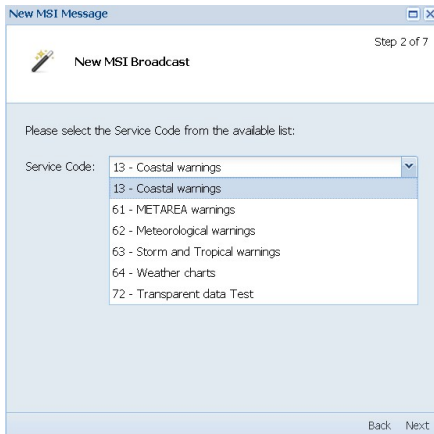

Figure 17, – Select MET Service Code

4.6 Step 3 Priority Code

4.6.1 As illustrated below, in step 3 the MSIP can select the Priority Codes "Safety" or "Urgency".

Formatert: Kontroller staving og grammatikk

Formatert: Skrift: 9,5 pkt

Formatert: Mellomrom Før: 0 pkt., Linjeavstand: Enkel

Formatert: Skrift: 9,5 pkt

Formatert: Skrift: 9,5 pkt, Ikke Kursiv

Formatert: Blokkjustert, Linjeavstand: Enkel

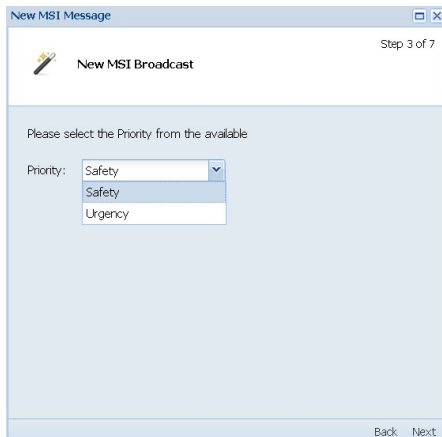

Figure 18 – Select Priority Code

4.7 Step 4 Area Type

4.7.1 In Step 4 the MSIP can select the area type: Circular Area, Rectangular Area, NAVAREA/METAREA, Coastal Area (within NAVAREA/METAREA), and Subarea (within NAVAREA/METAREA). The different Area Types are illustrated in Figures 18 to 21.

Formatert: Kontroller staving og grammatikk

Formatert: Skrift: 9,5 pkt

Formatert: Skrift: 9,5 pkt

Formatert: Mellomrom Før: 0 pkt., Linjeavstand: Enkel

Formatert: Skrift: 9,5 pkt, Ikke Kursiv

Formatert: Blokkjustert, Linjeavstand: Enkel

Formatert: Skrift: 9,5 pkt, Ikke Kursiv

Formatert: Skrift: 9,5 pkt, Ikke Kursiv

Figure 19 – Select Circular Area

4.7.2 To create a Circular Area, the centre of the Circular Area needs to be given by using 1) full figures for North and East and 2) by adding a "-" prior to the numbers symbols for South and West. For example, 51N 01E is "51 01". If this was to be 51S and 01W the MSIP would enter "-51 -01". The "Radius" is in Nautical Miles up to 999.

Formatert: Kontroller staving og grammatikk

Formatert: Skrift: 9,5 pkt, Ikke Kursiv

Formatert: Skrift: 9,5 pkt

Formatert: Mellomrom Før: 0 pkt., Linjeavstand: Enkel

Formatert: Skrift: 9,5 pkt

Formatert: Skrift: Kursiv

Formatert: Mellomrom Før: 0 pkt., Linjeavstand: Enkel

Formatert: Blokkjustert, Linjeavstand: Enkel

New MSI Message □ ×

Step 4 of 7

 New MSI Broadcast

Please select the area type and enter the corresponding parameters:

Area Type: Circular Rectangular Other

SW Corner:

Northings:

Eastings:

Back Next

Formatert: Kontroller staving og grammatikk

Figure 20.- Select Rectangular Area

4.7.3 To create a Rectangular Area, the South West corner of the Rectangular Area, followed by the maximum northing and easting in the same format as the Circular Area coordinates, needs to be given.

Formatert: Skrift: 9,5 pkt

Formatert: Skrift: 9,5 pkt

Formatert: Mellomrom Før: 0 pkt., Linjeavstand: Enkel

Formatert: Blokkjustert, Linjeavstand: Enkel

Formatert: Skrift: 9,5 pkt, Ikke Kursiv

Formatert: Skrift: 9,5 pkt, Ikke Kursiv

Formatert: Skrift: 9,5 pkt, Ikke Kursiv

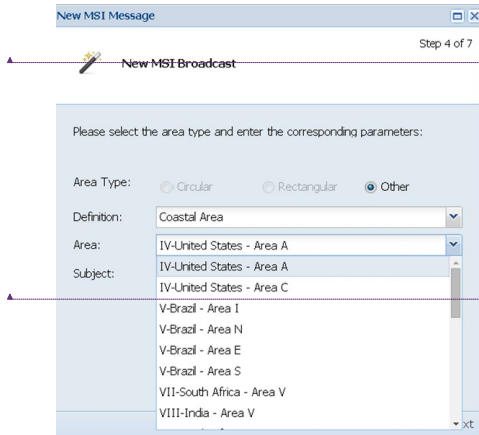

Formatert: Kontroller staving og grammatikk

Formatert: Skrift: 9,5 pkt

Formatert: Mellomrom Før: 0 pkt., Linjeavstand: Enkel

Figure 21, – Select Coastal area

Formatert: Skrift: 9,5 pkt

Formatert: Skrift: Kursiv

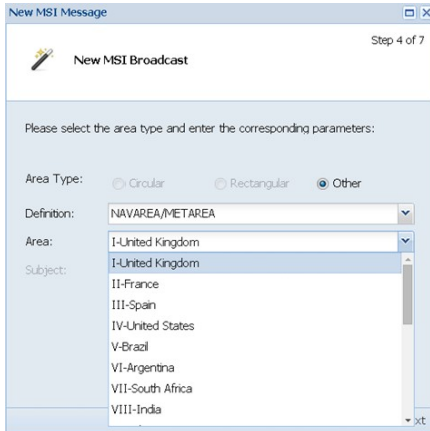

Figure 22.- Select NAVAREA/METAREA

4.8 Step 5 Date, Time and Repetition Code

4.8.1 The figure below illustrates step 5, which enables enhanced MSI scheduling. The MSIP can select the start date and time the MSI message should be broadcasted. If no date and time are selected, the MSI will be broadcasted immediately. In addition, in step 5 the MSIP can select the appropriate "Repetition Code" indicating how often the MSI messages is broadcasted.

Formatert: Kontroller staving og grammatikk

Formatert: Skrift: 9,5 pkt

Formatert: Skrift: 9,5 pkt

Formatert: Blokkjustert, Linjeavstand: Enkel

Formatert: Skrift: 9,5 pkt, Ikke Kursiv

Formatert: Skrift: 9,5 pkt, Ikke Kursiv

Formatert: Skrift: 9,5 pkt, Ikke Kursiv

Formatert: Skrift: 9,5 pkt, Ikke Kursiv

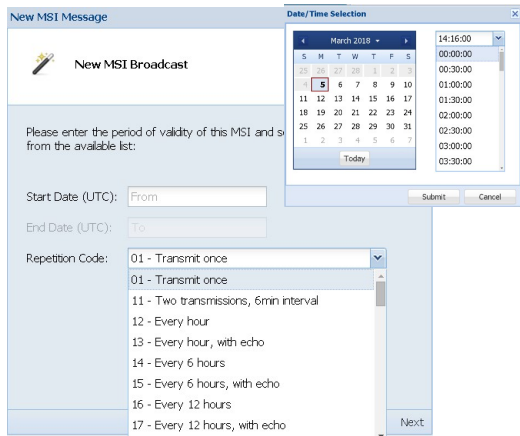

Figure 23.- Start date, time and repetition code

4.9 Step 6 Text

4.9.1 Step 6 enables the MSIP to add the MSI text either by 1) typing the text, 2) copy and pasting the text in the text box or 3) uploading a file. There is no limit to the text space. The universal language of MSI is English.

Formatert: Kontroller staving og grammatikk

Formatert: Skrift: 9,5 pkt

Formatert: Skrift: 9,5 pkt, Ikke Kursiv

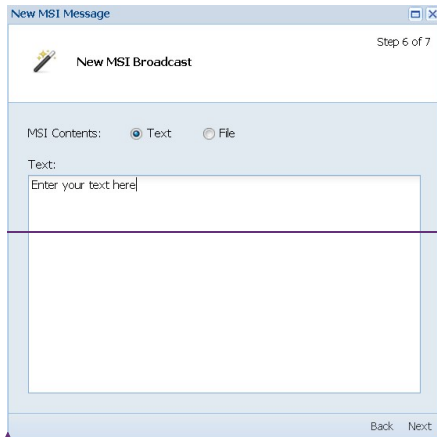

Figure 24. - Adding text

4.10 Step 7 Summary

4.10.1 Step 7 shows an overview of the MSI message created and gives the MSIP the option to check the message before broadcasting it. By clicking on "Finish", the MSIP will broadcast the MSI message. Each created MSI message will have a unique 6-digit reference number.

Formatert: Kontroller staving og grammatikk

Formatert: Linjeavstand: Enkel

Formatert: Skrift: 9,5 pkt

Formatert: Mellomrom Før: 0 pkt., Linjeavstand: Enkel

Formatert: Skrift: 9,5 pkt

Formatert: Skrift: 9,5 pkt, Ikke Kursiv

Formatert: Blokkjustert, Linjeavstand: Enkel

Formatert: Skrift: 9,5 pkt, Ikke Kursiv

Formatert: Skrift: 9,5 pkt, Ikke Kursiv

Formatert: Skrift: 9,5 pkt, Ikke Kursiv

Formatert: Skrift: 9,5 pkt, Ikke Kursiv

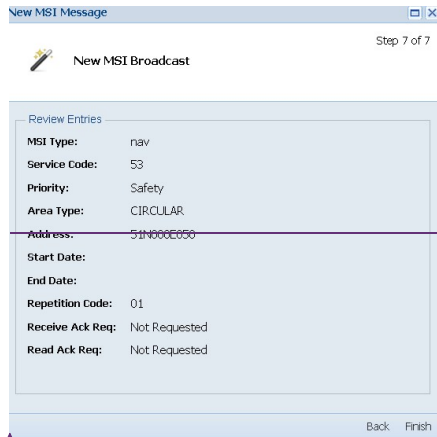

Figure 25 - MSI summary

5 Monitoring of MSI broadcasts

5.1 SafetyNET II offers the MSIP the option to view and monitor all created MSI messages under "MSI Messages". By clicking on "View MSIPs", the MSIP can , to view all MSI messages created and their status (i.e. scheduled, finished or cancelled).

Formatert: Kontroller staving og grammatikk

Formatert: Linjeavstand: Enkel

Formatert: Skrift: 9,5 pkt

Formatert: Mellomrom Før: 0 pkt., Linjeavstand: Enkel

Formatert: Skrift: 11 pkt, Fet, Ikke Kursiv

Formatert: Blokkjustert, Linjeavstand: Enkel

Formatert: Skrift: 9,5 pkt, Ikke Kursiv

Formatert: Skrift: 9,5 pkt, Ikke Kursiv

MSI List

Cancel

Reference Number	Type	Service Code	Area Type	Address	Priority	Repetition Code	Size	Start Date	End Date	Status	EGC Id
175050	Meteorol...	62	CIRCULAR	SINNOI...	safety	01	66	24/10/2015 15:44...	24/10/2015 15:44...	Scheduled	372
174950	Meteorology	61	HAVNET	62	distress	01	4	22/02/2015 09:43:00.0	21/02/2015 09:41:00.0	Cancelled	370
172250	Meteorology	62	CIRCULAR	SINNOIE	urgency	01	9	14/02/2015 05:00:00.0	13/02/2015 09:15:05.0	Cancelled	369
166302	Navigational	52	CIRCULAR	SINNOIE	urgency	01	170	23/09/2015 08:51:20.7	23/09/2015 08:51:20.7	Finished	319
166381	Meteorology	62	CIRCULAR	SINNOIE	urgency	01	174	23/09/2015 08:49:26.8	23/09/2015 08:49:26.8	Finished	318
166380	Navigational	52	CIRCULAR	SINNOIE	safety	01	173	23/09/2015 08:46:48.3	23/09/2015 08:46:48.3	Finished	317
166379	Meteorology	62	CIRCULAR	SINNOIE	safety	01	173	23/09/2015 08:42:33.8	23/09/2015 08:42:33.8	Finished	316

Detail Acknowledge

Text: This is a test message from Innmarst. No action is required.

Figure 26 - MSI Monitoring

5.2 In order to ensure the integrity of the MSI being broadcast, MSIP's must monitor the broadcasts which they originate in accordance to IMO resolution A.706(17), as amended. Monitoring is especially important in a highly automated system, which is dependent on careful adherence to procedure and format.

5.3 This shall be accomplished by the installation of an EGC receiver to enable each MSI provider to:

1. Check that the message has been broadcast;
2. Confirm that the message is received correctly;
3. Ensure that cancellation messages are properly executed; and
4. Observe any unexplained delay in the message being broadcast.

5.4 EGC receivers only display or print messages on the first occasion they are received. Therefore, in order for MSIP's to confirm that all messages in force are still being transmitted, and that cancelled messages are no longer being transmitted, the EGC receiver used by the MSI provider to monitor their SafetyNET II broadcasts should be powered down (including the transceiver), and re-booted at regular intervals, wherever this is possible.

Formatert: Kontroller staving og grammatikk

Formatert: Blokkjustert, Innrykk: Hengende: 1 cm, Linjeavstand: Enkel

Formatert: Skrift: 9,5 pkt

Formatert: Mellomrom Før: 0 pkt., Linjeavstand: Enkel

Formatert: Skrift: 9,5 pkt, Ikke Kursiv

Formatert: Blokkjustert, Linjeavstand: Enkel

Formatert: Skrift: 9,5 pkt, Ikke Kursiv

Formatert: Blokkjustert, Mellomrom Før: 0 pkt., Linjeavstand: Enkel

Formatert: Blokkjustert, Linjeavstand: Enkel

Formatert: Skrift: 9,5 pkt, Ikke Kursiv

Formatert: Skrift: 9,5 pkt, Ikke Kursiv

Formatert: Skrift: 9,5 pkt, Ikke Kursiv

5.5 Alternatively, MSIP's should consult their equipment supplier for specialist EGC monitoring software, which would not require the MES to be re-booted.

Formatert: Skrift: 9,5 pkt, Ikke Kursiv

Formatert: Skrift: 9,5 pkt, Ikke Kursiv

6 Cancellation of MSI broadcast

Formatert: Skrift: 11 pkt, Fet, Ikke Kursiv

6.1 MSIPs can cancel all created MSI messages under "MSI Messages". By clicking on "View MSIPs", the MSIP can cancel the MSI message by clicking on the "Cancel" button in the left top corner. The MSI message will be cancelled and the status will change to "Cancelled".

Formatert: Skrift: 9,5 pkt, Ikke Kursiv

Formatert: Skrift: 9,5 pkt, Ikke Kursiv

Reference Number	Type	Service Code	Area Type	Address	Priority	Repetition Code	Size	Start Date	End Date	Status	EGC M
174908	Meteorolog	62	CIRETAR	SINNOE	safety	01	86	24/10/2015 15:44:...	24/10/2015 15:44:...	Scheduled	372
174990	Meteorolog	61	NAMNET	62	distress	01	4	22/10/2015 09:43:00.0	21/10/2015 09:41:00.0	Cancelled	370
172258	Meteorolog	62	CIRCULAR	SINNOIE	urgency	01	9	14/10/2015 15:00:00.0	13/10/2015 09:19:35.0	Cancelled	355
166362	Navigationel	52	CIRCULAR	SINNOIE	urgency	01	170	23/09/2015 08:51:00.7	23/09/2015 08:51:00.7	Finished	319
166281	Meteorolog	62	CIRCULAR	SINNOIE	urgency	01	174	23/09/2015 08:49:26.0	23/09/2015 08:49:26.0	Finished	318
166380	Navigationel	52	CIRCULAR	SINNOIE	safety	01	173	23/09/2015 08:46:48.3	23/09/2015 08:46:48.3	Finished	317
166378	Meteorolog	62	CIRCULAR	SINNOIE	safety	01	173	23/09/2015 08:42:33.8	23/09/2015 08:42:33.8	Finished	316

Detail Acknowledges

Text: This is a test message from Innmarst. No action is required.

Formatert: Kontroller staving og grammatikk

Formatert: Skrift: 9,5 pkt, Ikke Kursiv

Formatert: Blokkjustert, Innrykk: Venstre: -1 cm, Linjeavstand: Enkel

Figure 27, – MSI Cancellation

7 SafetyNET II setup

Formatert: Mellomrom Før: 0 pkt., Linjeavstand: Enkel

Formatert: Skrift: 9,5 pkt

Formatert: Skrift: 11 pkt, Fet, Ikke Kursiv

Formatert: Blokkjustert, Linjeavstand: Enkel

7.1 Annex 2 describes the authorization, certification and registration of SafetyNET information providers. After the authorisation, certification and registration of the MSIP, individual log-ins to the SafetyNET II portal will be provided for each MSIP authorized contact specified at the time of service setup.

Formatert: Skrift: 9,5 pkt, Ikke Kursiv

Formatert: Skrift: 9,5 pkt, Ikke Kursiv

7.2 A secure password will be provided to each MSIP. This password can be changed by the user after the login on the SafetyNET II portal.

Formatert: Skrift: 9,5 pkt, Ikke Kursiv

Formatert: Skrift: 9,5 pkt, Ikke Kursiv

7.3 In case the password is lost, the MSIP can request a new password through the SafetyNET II portal. Care of the password is the responsibility of the MSIP.

7.4 Additional SafetyNET II user accounts can be created. Management of user accounts will be the responsibility of the MSIPs on behalf of their Subscribers. Registered information providers shall take into account the need for contingency planning.

Formatert: Skrift: 9,5 pkt, Ikke Kursiv

8 SafetyNET II maintenance

Formatert: Skrift: 11 pkt, Fet, Ikke Kursiv

8.1 Inmarsat may periodically implement changes, which could consist of firmware upgrades, equipment upgrades or network changes. The implementation may lead to a scheduled outage, which will be governed under the processes detailed below.

Formatert: Skrift: 9,5 pkt, Ikke Kursiv

Formatert: Skrift: 9,5 pkt, Ikke Kursiv

Formatert: Skrift: 9,5 pkt, Ikke Kursiv

8.2 Inmarsat will provide the customer with written notice of any scheduled maintenance that may affect services at least five business days beforehand.

8.3 Inmarsat shall notify the customer as soon as possible, at the latest within one hour, after beginning any emergency unscheduled service-affecting maintenance activity, together with the reason for the activity and information on how long service will be affected.

8.4 In any situation where maintenance is planned a notification will be sent to pre-defined email addresses provided by the customer. This list can be altered and additional email addresses can be added at any time when instructed by the customer.

Formatert: Skrift: 9,5 pkt, Ikke Kursiv

8.5 Inmarsat Customer Support will provide notice, as soon as possible, in any situation where there is degradation of service, an unplanned maintenance or any type of loss of service that could not have been planned for.

Formatert: Skrift: 9,5 pkt, Ikke Kursiv

Formatert: Skrift: 9,5 pkt, Ikke Kursiv

8.6 The notice will define:

- The date of the scheduled outage, as well as time of day, stated in UTC.
- The services impacted
- The expected duration
- The estimated resolution time
- The Ocean Regions affected
- Reason for planned or unplanned maintenance

Formatert: Blokkjustert, Mellomrom Før: 0 pkt., Etter: 0 pkt., Linjeavstand: Enkel, Punktmerket + Nivå: 1 + Justert ved: 0,63 cm + Innrykk ved: 1,27 cm

Formatert: Skrift: 9,5 pkt, Ikke Kursiv

Formatert: Skrift: 9,5 pkt, Ikke Kursiv

8.7 In cases of planned and unplanned maintenance, Inmarsat will provide a notice of restoration, as soon the information is available, including any remedial action or service recovery protocols, which may be required by the customer.

Formatert: Skrift: 9,5 pkt, Ikke Kursiv

Formatert: Blokkjustert, Mellomrom Før: 0 pkt., Etter: 0 pkt., Linjeavstand: Enkel

9 SafetyNET II Customer Support

Formatert: Skrift: 11 pkt, Fet, Ikke Kursiv

Formatert: Blokkjustert, Linjeavstand: Enkel

9.1 Inmarsat provides 24/7/365 customer support through its regional Support Centres with specialist teams, to provide resolution of customer issues. Inmarsat Customer Support is the single point of contact for the customer for all issues regardless of which internal Inmarsat department may be involved in resolving a problem.

Formatert: Skrift: 9,5 pkt, Ikke Kursiv

Formatert: Skrift: 9,5 pkt, Ikke Kursiv

Formatert: Skrift: 9,5 pkt, Ikke Kursiv

Formatert: Skrift: 9,5 pkt, Ikke Kursiv

9.2 Customer support can be contacted directly by telephone or email. Upon receipt of an email or phone call a ticket will be opened and a unique case number will be assigned and provided to the customer. By keeping the case number in the subject line all communication related to the case will be captured within the ticket for future reference and reporting purposes. All Customer support cases follow a structured fault resolution and escalation procedure.

Formatert: Skrift: 9,5 pkt, Ikke Kursiv

9.3. For a detailed description of all Customer Support processes, problem prioritisation policies, Service Level Agreement details and all other relevant information please contact the Inmarsat Global Operations Centre:

Tel: +1 709-748-4226 Worldwide

Fax: +1 709-748-4320 Worldwide

Tel: +1 800-563-2255 Toll free in N. America

Fax: +1 877-748-4320 Toll free in N. America

Email: GlobalCustomerSupport@inmarsat.com

Formatert: Skrift: 9,5 pkt, Ikke Kursiv

Formatert: Skrift: 9,5 pkt, Ikke Kursiv

Formatert: Skrift: 9,5 pkt, Ikke Kursiv

Formatert: Skrift: 9,5 pkt, Ikke Kursiv

Formatert: Skrift: 9,5 pkt, Ikke Kursiv

Formatert: Blokkjustert, Mellomrom Før: 0 pkt., Linjeavstand: Enkel

Formatert: Skrift: 9,5 pkt, Ikke Kursiv

Formatert: Skrift: 9,5 pkt, Ikke Kursiv

Formatert: Blokkjustert

Annex 7

MSI receiver specifications, FleetBroadband

These technical requirements were defined by Inmarsat for equipment manufacturers and have been extracted from the System Definition Manual (SDM) for the Inmarsat BGAN communications system.

Maritime Safety Information (MSI) receive facilities are used by SOLAS Convention ships as well as ships not required to comply with the requirements of the SOLAS Convention, as amended. It should be noted that MSI receive facilities intended to meet SOLAS Convention requirements must comply with the IMO Recommendation on Performance Standards for Enhanced Group Call Equipment contained in resolution A.664(16) and the Amendments to the Revised Performance Standards for Enhanced Group Call (EGC) equipment in resolution MSC.431(98), as amended.

The specific guidance given in this annex has been carefully coordinated to ensure that the automatic functions of the SafetyNET II receiver work properly. Satellite Access Station providing FleetBroadband services for the GMDSS must comply with all relevant aspects of the Inmarsat BGAN SDM, including provision of the MSI SafetyNET II services.

Technical requirements for Enhanced Group Call receivers for SOLAS-compliant MESS

1 MSI SafetyNET receivers for SOLAS installations

1.1 Background

The Global Maritime Distress and Safety System (GMDSS) is a radiocommunication system based on satellite and terrestrial technology, designed to improve communications relating to distress and safety of life at sea. It was adopted by the International Maritime Organization (IMO) in 1988, in the form of Amendments to the International Convention for the Safety of Life at Sea (SOLAS), 1974

Formatert: Utheving

Formatert: Annex (Head_text)

Formatert: Utheving

Formatert: Utheving

Formatert: Utheving

Formatert: Utheving

and came into effect on 1 February 1992. Implementation was completed on 1 February 1999.

It is the responsibility of national Administrations to determine whether a radio installation on board a ship meets the SOLAS requirements. This is done by national Type Acceptance or Approval testing of the sub-systems included in the installation and by inspection of the complete installation by a radio surveyor.

National Type Acceptance testing for SOLAS equipment is usually based on GMDSS specifications and procedures prepared by IMO and the International Electrotechnical Commission (IEC) on their behalf, although other national or regional specifications may be invoked as well.

IMO and IEC documents, which are identified in section 1.2, do not only summarize the general requirements for GMDSS equipment, but also the special requirements for MSI SafetyNET II receivers for use in SOLAS installations, as specified by IMO/IEC.

A number of the Inmarsat specifications have been completely revised to reflect the latest IMO/IEC requirements, for example, electromagnetic compatibility and environmental requirements.

1.2 Principal relevant documents

For Inmarsat Fleet Safety GMDSS compliant UTs with MSI functions, the principal relevant documents in addition to the Inmarsat BGAN SDM are:

- .1 [Performance Standards for Enhanced Group Call Equipment – Annex: Recommendation on Performance Standards for Enhanced Group Call Equipment](#), published by IMO as resolution [A.664\(16\)](#), as amended.
- .2 [Amendments to the Revised Performance Standards for Enhanced Group Call \(EGC\) equipment](#), published by IMO as resolution [MSC.431\(98\)](#), as amended.
- .3 [General Requirements for Shipborne Radio Equipment Forming Part of the Global Maritime Distress and Safety System \(GMDSS\) and for Electronic Navigational Aids](#), published by IMO as resolution [A.694\(17\)](#).
- .4 [Performance Standards for Inmarsat FleetBroadband Ship Earth Stations Capable of Transmitting and Receiving Direct-](#)

Formatert: Utheving

printing Communications – Annex: Recommendation on Performance Standards for Inmarsat FleetBroadband Ship Earth Stations Capable of Transmitting and Receiving Direct-printing Communications, published by IMO as resolution A.807(19), as amended by resolution MSC.68(68), Annex 4.

- .5 Performance standards for a Ship Earth Station for use in the GMDSS, published by IMI as resolution MSC.434(98), as amended.
- .6 Shipborne Radio Equipment Forming Part of the Global Maritime Distress and Safety System and Marine Navigational Equipment, published by the IEC as IEC 60945.
- .7 Global Maritime Distress and Safety System (GMDSS) – Part 4: Inmarsat FleetBroadband UT and Inmarsat Maritime Safety Information (MSI) Equipment – Operational and Performance Requirements, Methods of Testing and Required Test Results, published by the IEC as IEC 61097-4.
- .8 Maritime Design and Installation Guidelines (DIGs), Annex B, issue 6 of April 2008 published by Inmarsat at: <http://www.inmarsat.com/Maritimesafety/DIGs.pdf>

Formatert: Innrykk: Venstre: 1 cm, Hengende: 0,75 cm

Formatert: Uttheving

Formatert: Innrykk: Venstre: 0,75 cm, Hengende: 1 cm

Formatert: Uttheving

Formatert: Uttheving

Feltkode endret

2 Introduction

2.1 Maritime Safety Information

Maritime Safety Information is a message broadcast service transmitted over the BGAN communications system. The service allows terrestrial information providers to pass messages or data to UTs with Maritime Safety Terminal (MST) through the BGAN SASs. The messages are processed at the addressed SASs, which transmits them on the broadcast channel.

2.2 MSI receiver

An MSI receiver is defined as a Receiver function in the Maritime Safety Terminal connected to the FleetBroadband Terminal via the MSTI - interface. This MST provides an MSI capability in addition to ship-to-ship and ship-to-shore messaging capabilities.

2.3 Type approval

The Inmarsat BGAN SDM presents the technical requirements and recommendations for an MST receiver. These requirements must be satisfied before the equipment can be utilized in the Inmarsat system. Procedures for type approval by Inmarsat of a manufacturer's design are provided in a complementary document entitled, FB Alpha Beta Testing, produced by Inmarsat.

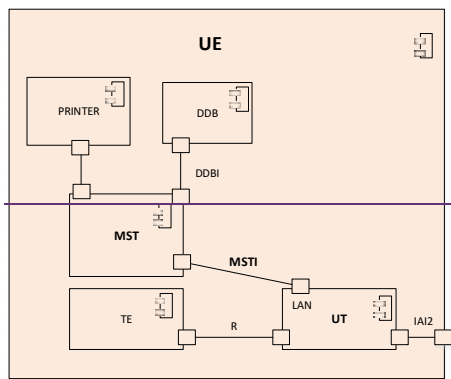

Figure 28 – Extended Architecture of the User Equipment
(FleetBroadband Terminal)

3 General requirements

3.1 Mandatory capabilities

The mandatory capabilities of SafetyNET li receivers for SOLAS applications are:

- .1 continuous reception of broadcast channel and processing of the information according to the MSI message protocol
- .2 automatic recognition of messages directed to fixed and

Formatert: Kontroller staving og grammatikk

absolute geographical areas and service codes as selected by the receiver operator or based upon input(s) from navigational equipment;

.3 SafetyNET receivers meet the requirements of IEC 61097-4 and IEC 60945; and

.4 Where automatic updates are not available, provision is made for a visual indication if the ship's position has not been updated during the last 12 hours. It is only possible to reset this indication by revalidating the ship's position.

4 Broadcast channel selection

4.1 General

MSI receivers are a function of the Maritime Safety Terminal that is connected to FleetBroadband. FleetBroadband terminals permanently monitor the broadcast system information based on a dynamic allocation of channel frequencies.

4.2 Global broadcast scanning

Automatic scanning of the system information and automated satellite selection is a mandatory feature of all FleetBroadband UTs. In the event of loss of forward carrier connectivity from the satellite exceeding 30s, the UT shall automatically attempt to retune to another satellite and re-establish the link to the ground.

5 Message-processing requirements

5.1 General

Acceptance or rejection of the MSI service code types is under operator control, except that receivers always receive navigational warnings; meteorological warnings, SAR information and shore-to-ship distress alerts, which are directed to a fixed or absolute geographical area within which the receiver is situated.

5.2 Display devices

5.2.1 Message display

The display is capable of presenting at least 40 characters per line of text. The MSI receiver ensures that if a word cannot be accommodated in full on one line it is transferred to the next line.

5.2.2 Status display

The MST is able to provide indication on the link status (i.e. various level of connectivity to the Inmarsat network) which could trigger alarms to the users.

5.3 Printer requirements

A printer is required for a SOLAS SafetyNET II receiver. Received MSI messages may be stored for later printing with an indication to the operator that the message has been received. However, distress or urgency priority calls are directly printed as well as stored. Means are also provided not to print or store the same MSI message after it has been received error-free and printed.

Messages are not printed until completely received.

A local audible alarm is sounded to give advance warning of a printer "paper-low" condition.

All SafetyNET messages are annotated with the date and time (UTC) of reception. This information is displayed or printed with the message.

5.4 Character codes

For the MSI service, the International Reference Version of the International Alphabet 5 (IA5), also known as ASCII (a standard alphanumeric character set based on 7-bit codes) is used.

5.5 Operator control

The following control functions and displays are provided as a minimum:

.1 selection of MSI carrier frequency;

For SOLAS SafetyNET receivers:

.2 means of inputting the following information:

1. MES's position coordinates;
2. current and planned (additional) NAVAREA(s)/METAREA(s);
3. current and planned coastal warning area (B₁ Code); and
4. coastal warning subject indicator character (B₂ Code).

Receivers are fitted with operator controls to allow the operator to select desired geographical areas and message categories. Details of the geographical areas and message categories which have been selected for reception by the operator are readily available.

5.6 MSI receiver memory capacity requirements

The MSI receiver shall be capable of storing safety related activity and messages.

Information stored should include:

- Date/time of activity
- Activity type (message received, etc. plus priority)
- Message/MSI header information
- Message/MSI size and contents
- Date/time of operator acknowledgement for received Distress and Urgency messages/MSI
- Date/time when operator read received messages/MSI (no date/time means not read)
- Message history

The database can record at least 500 messages (received/MSI) of average 500 characters (printable and non-printable). It should not be possible for the user to erase messages from the memory. If the database becomes full the oldest messages should be overwritten by new messages.

The user should be able to tag individual messages for permanent retention. These messages may occupy up to 25% of the available database and should not be overwritten by new messages. When no longer required, the user should be able to remove the tag on these 'saved' messages which may then be overwritten in the normal manner.

5.7 MSI receiver addressing

The five basic methods of addressing MSI receivers are:

1. All-mobiles call (Inmarsat only);
2. Inmarsat system message addressing (Inmarsat only);
3. Fixed geographical area (NAV/METAREA);
4. Temporary area determined by MSI provider - circular or rectangular;
5. Coastal warning area;

The type of address used in the header of an MSI packet is uniquely determined by the "C₂" service code field.

5.8 Message identification

All messages are transmitted with a unique reference number and vendor ID. Each subsequent transmission of the message contains the original sequence number. This facility allows multiple printing of repeated messages to be inhibited.

5.9 Geographical area addressing

Geographical area addressing refers to messages transmitted to UTs in a particular area. The area may be expressed in terms of a fixed, pre-defined area such as the NAVAREA/METAREA, or satellite coastal warning area, or in terms of an absolute geographical address expressed as latitude and longitude coordinates on the surface of the earth. An absolute geographical area address is a representation of a closed boundary on the surface of the earth given in the address field of the message header. The receiver recognises two forms of absolute geographical addressing: rectangular and circular. Each form is specified in terms of an absolute position in latitude and longitude and further parameters that completely specify the boundary.

In order to process a geographical area address, the receiver shall be programmed with the UT's current position. The position may be entered automatically from an integrated or external navigation aid or entered manually. The receiver provides notification to the operator when the position has not been updated for four hours. If the UT's position has not been updated for more than 12 hours or is unknown, **ALL** MSI messages will be printed or stored in the memory.

A geographical area address is considered valid for a particular UT if its current position falls inside or on the boundary specified by the address. It is a mandatory requirement that the operator be able to select more than one area, so that messages directed to other area(s) of interest can be provided. It is recommended that the operator be able to select at least four areas.

6 Link performance monitoring

The MSI receiver continuously monitors the received bulletin board whenever it is tuned and synchronized to the SAS. The receiver stores at least 500 messages (received MSI) of average length 500 characters (printable and non-printable) in this database. It should not be possible for the user to erase messages from the memory. If the database becomes full, the oldest messages should be overwritten by new messages.

7 Alarms and indications

The following alarms and indications are provided at a SOLAS MSI receiver and meet the operational requirements for alarms stated in IEC 61097-4.

7.1 Distress/Urgency priority call alarm

For SOLAS MSI receivers:

Provision is made for a specific audible alarm and visual indication at the position from which the ship is normally navigated to indicate receipt of MSI messages with distress or urgency priority. It is not possible to disable this alarm and it is only possible to re-set it manually, and then only from the position where the message is displayed or printed.

7.2 Other alarms and indications

1. USIM Not present
2. Registration Failure
3. Loss of Signal
4. PS connection failure
5. CS connection failure

6. Distress Voice Call Failure

7. Printer Failure

Additional alarms and indications may be provided at the manufacturer's discretion.

8 Electromagnetic compatibility

The interference and electromagnetic compatibility requirements of IEC 60945 applies.

9 Environmental conditions

SOLAS MSI receivers shall operate satisfactorily under the environmental conditions specified in the SDM. The latest issues of IEC 61097-4 and IEC 60945 apply.

10 Navigational interface

In order that a receiver's position may be automatically updated, receivers may be equipped with an interface to navigational instruments. A suggested standard interface is in IEC 61162, Part 1 (NMEA 0183) Standard for Interfacing Electronic Marine Navigational Devices.

Note: All FleetBroadband UTs have an integrated navigational receiver.

Annex 8

Procedure for amending the International SafetyNET Manual

1 Proposals for amendment or enhancement of the **International SafetyNET Services Manual** should be submitted to the IMO Maritime Safety Committee through the Sub-Committee on Navigation, Communications and Search and Rescue (NCSR).

Formatert: Uttheving

Formatert: Uttheving

2 Amendments to this Manual should normally be approved at intervals of approximately two years or at such longer periods as determined by the Maritime Safety Committee at the time of adoption. Amendments approved by the Maritime Safety Committee will be notified to all concerned, will provide at least 12 months' notification and will come into force on 1 January of the following year.

3 The agreement of the International Hydrographic Organization, International Mobile Satellite Organization, the World Meteorological Organization and the active participation of other bodies should be sought, according to the nature of the proposed amendments.