



# KONGSBERG MARITIME

**12th MACHC Meeting  
5th to 9th December 2011  
Basseterre, St. Kitts**

**By Jan Haug Kristensen  
Regional Manager Americas, KM Subsea Sales & Marketing**



**KONGSBERG**

**WORLD CLASS – through people, technology and dedication**



# Capacity Building in the MACHC Region

- General overview of Kongsberg Maritime AS
- 10th MACHC Meeting in Bridgetown, Barbados (2009)
- 2011 Hydrographic Technical Seminar in Havana, Cuba (KM & Caris)
- 2011 MACHC Hydrographic Training, Antigua
- 2011 IHO Workshop in Haiti
- Summary and Conclusions

# Kongsberg Group



KONGSBERG

Number of employees:  
**App. 5 500 +**



Kongsberg Maritime



Kongsberg Defence & Aerospace

# KONGSBERG - operations in more than 30 countries



KONGSBERG



# KONGSBERG Maritime Subsea

## Kongsberg Maritime Subsea

Hydrography



AUV



UNAV



Naval



Fishery



# Kongsberg Maritime AS Technology Platform



KONGSBERG

Application:



Fishery &  
Fishery Research

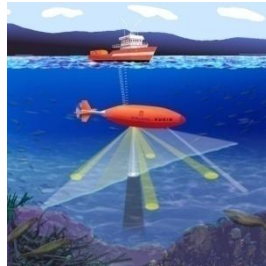

AUV

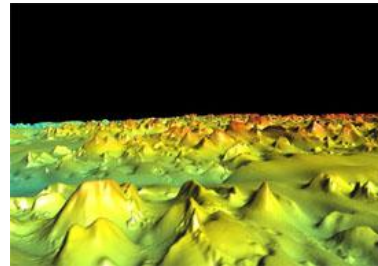

Hydrography

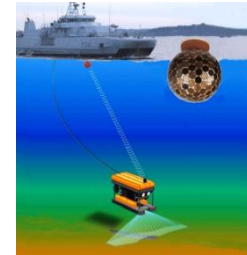

UW Nav.



Naval Sonars

Products:

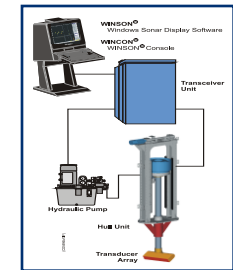
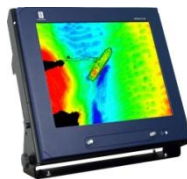

Common  
Technology:



# Capacity Building, Technical Cooperation, and Survey Demonstration Workshop



## at the 10<sup>th</sup> Meso American Caribbean Hydrographic Commission Meeting



KONGSBERG

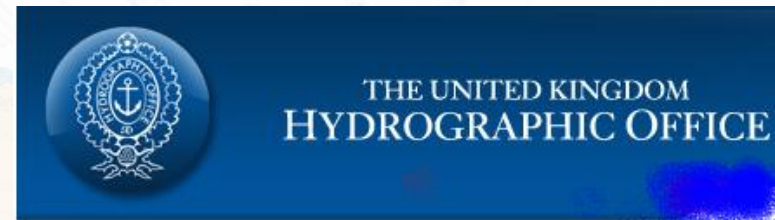

*caris*<sup>®</sup>

CAPT Bill Fergusson  
Port of Bridgetown  
Barbados

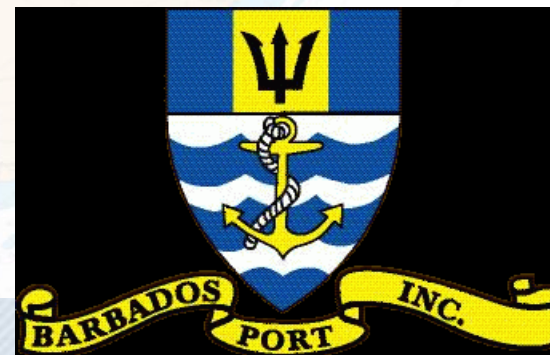

SEE FULL PICTURE

# Good Idea

Taking advantage of an opportunity...



KONGSBERG

- Attendance by 25 Regional States and International Organizations
- Substantial commitment of resources by participants



THE FULL PICTURE



# Resource Support



KONGSBERG

- Kongsberg – Equipment and Personnel
  - Kongsberg EM3002 and full installation kit
  - Equipment shipped from Norway to Barbados and return
  - Engineer for installation supervision and lead on survey operations
- CARIS – Data Processing and Personnel
  - CARIS HIPS/SIPS and BASE Editor processing software
  - Hydrographer for survey planning and data processing
- Port of Bridgetown – Survey Platform
  - Port of Bridgetown provided the Pilot Vessel, *Carlisle Bay*, crew, and fuel for survey operations
  - Survey requirements
- UKHO – Background Data
  - Provided latest Raster Navigational Charts of Barbados coastal waters



# Substantive Content

## Kongsberg – Equipment and Survey



- Full installation and integration of EM3002 Multibeam Echosounder (MBES)
- Integration of all equipment used for positioning of bathymetry data
- Calibration of all equipment
- Consideration of environmental constraints
- At Sea Demonstrations
- Survey operations



THE FULL PICTURE

# Substantive Content

## CARIS – Data processing



- Multibeam bathymetry
- survey line planning
- High volume data processing using CARIS HIPS/SIPS and BASE Editor software
  - Motion Corrections
  - Water Level Correction
- Survey operations
- Provided fully processed data to Port of Bridgetown

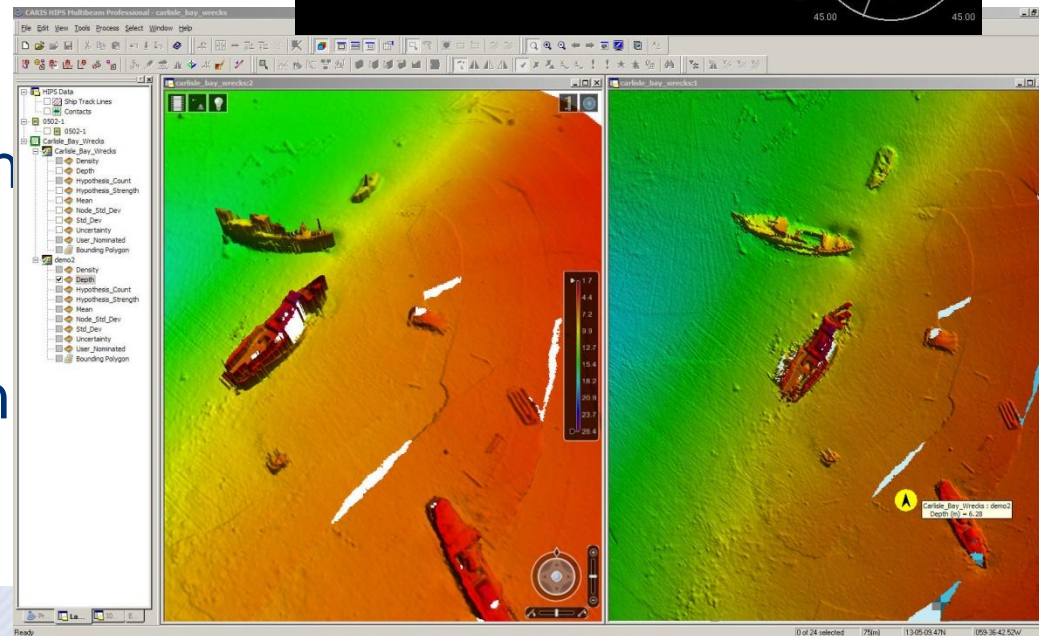
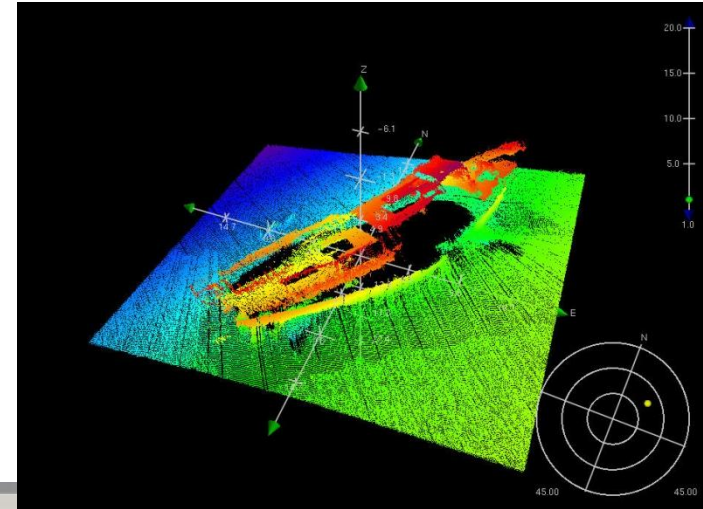

# The Workshop



- Survey area and lines planned in conjunction with Port of Bridgetown to meet immediate survey requirement
- Prior to the meeting: 1 week of system setup and acceptance testing onboard Pilot vessel
- During the week groups of 2 or 3 attended on board
- Data processing during week, completed and reviewed by last day of meeting → Industry Day
- Bathymetry dataset delivered to port of Bridgetown

# Survey Areas along the Barbados Coast



- Spring Garden
- Harbour
- Careenage
- Carlisle Bay

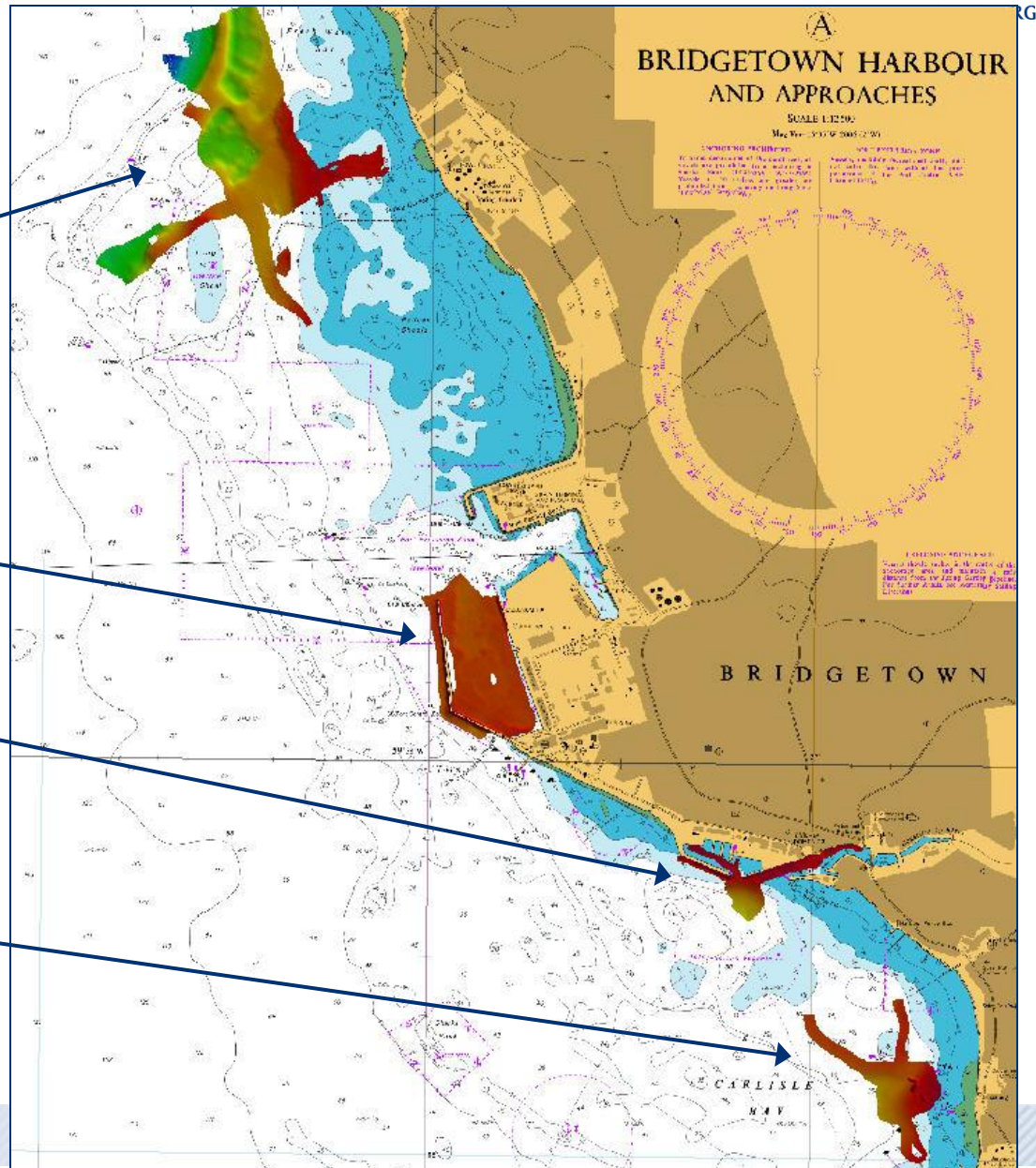

# Survey Results - Examples



KONGSBERG

- Creation of raster and vector products as deliverables to the Port

Carlisle Bay

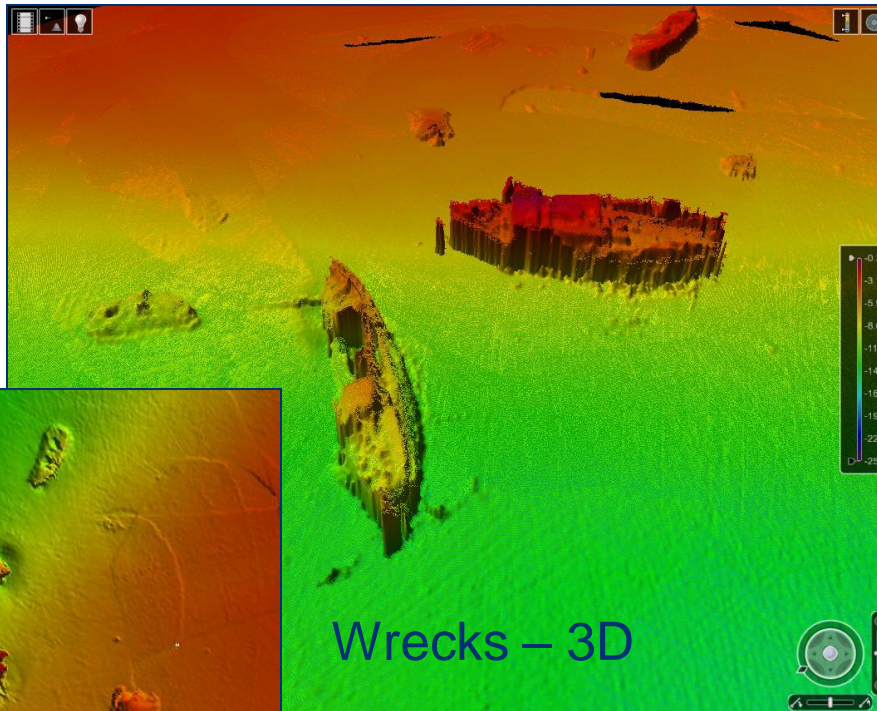

Wrecks – 2D

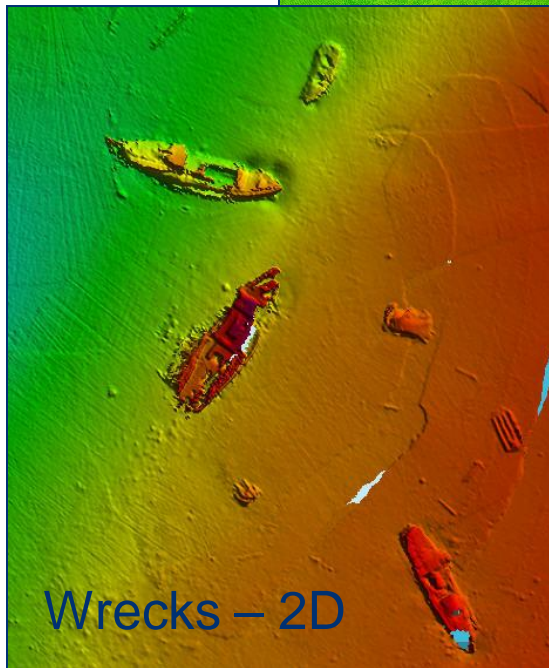

Spring Garden –  
Soundings and Contours

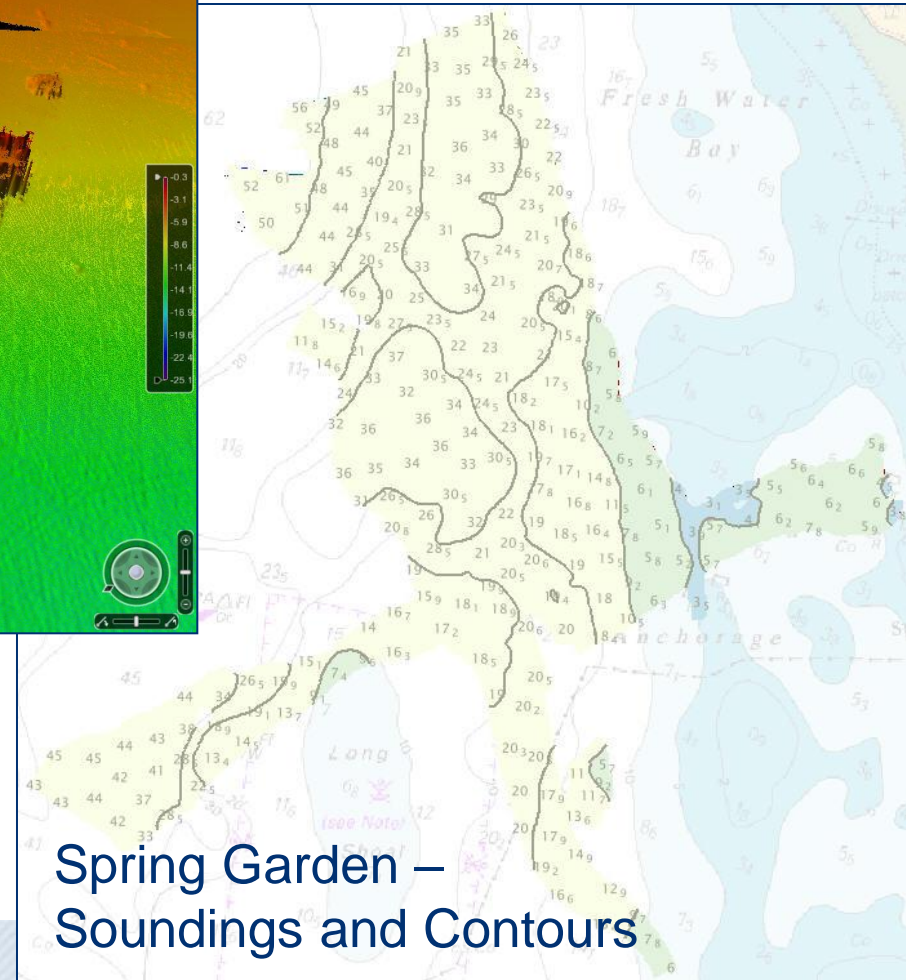

# Survey Results - Examples

- Data analysis

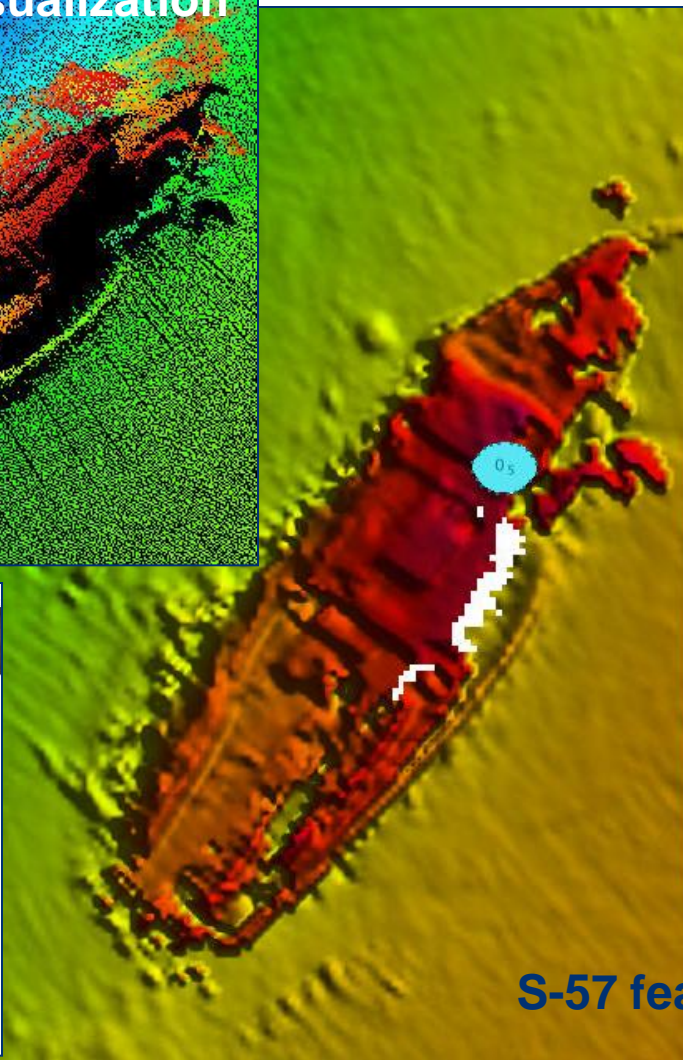
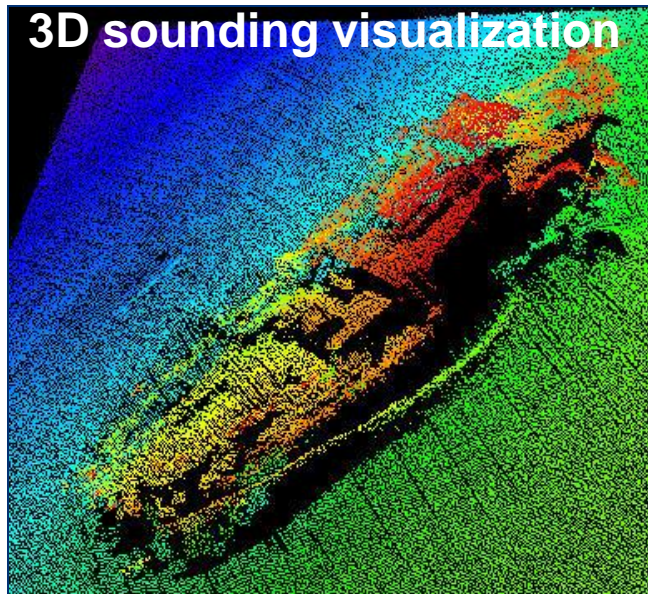

Acronym	Name	Value
SCAMIN	Scale minimum	
SCAMAX	Scale maximum	
CATWRK	Category of wreck	dangerous wreck
CONRAD	Conspicuous, radar	
CONVIS	Conspicuous, visually	
EXPSOU	Exposition of sounding	
HEIGHT	Height	
NOBJNM	Object name in national lang	
OBJNAM	Object name	
QUASOU	Quality of sounding measure	depth known
SOUACC	Sounding accuracy	0.748031 ft
STATUS	Status	
TECSOU	Technique of sounding meas	found by multi-beam
VALSOU	Value of sounding	1.919291 ft
VERACC	Vertical accuracy	
VERDAT	Vertical datum	
VERLEN	Vertical length	
WATLEV	Water level effect	always under water/submerged
NTXTDS	Textual description in nation	
PICREP	Pictorial representation	wreck_wo_divers.jpg;wreck_geobar_image.jpg
TXTDSC	Textual description	Carlisle Bay Wrecks Area, Port of Bridgetown, Bar
INFORM	Information	
NINFOM	Information in national langu	
RECDAT	Recording date	20091105
RECIND	Recording indication	
SORDAT	Source date	20091105
SORIND	Source indication	BB, 1C,reprt,none

S-57 feature data attribution

# Survey Results - Examples



KONGSBERG

- Identification of Bathymetry differences from chart in Spring Garden area

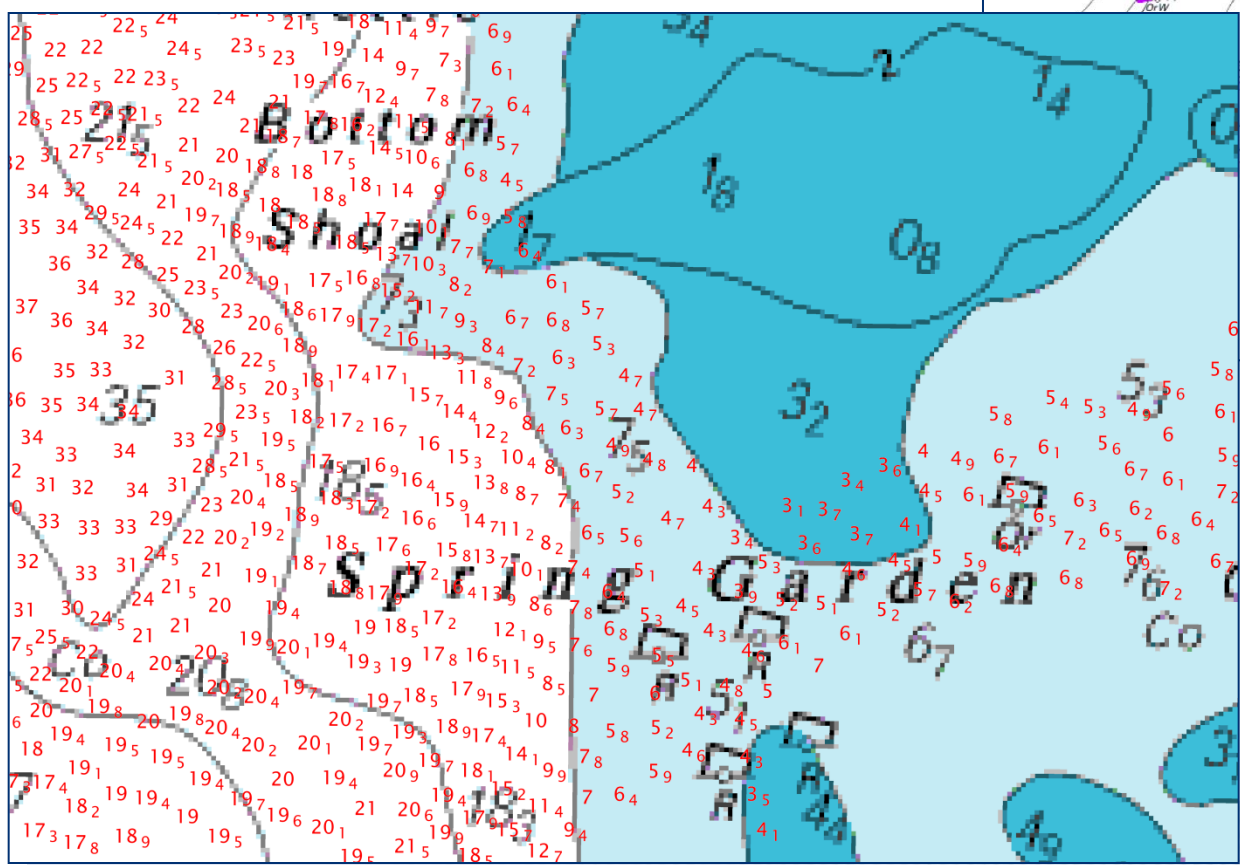
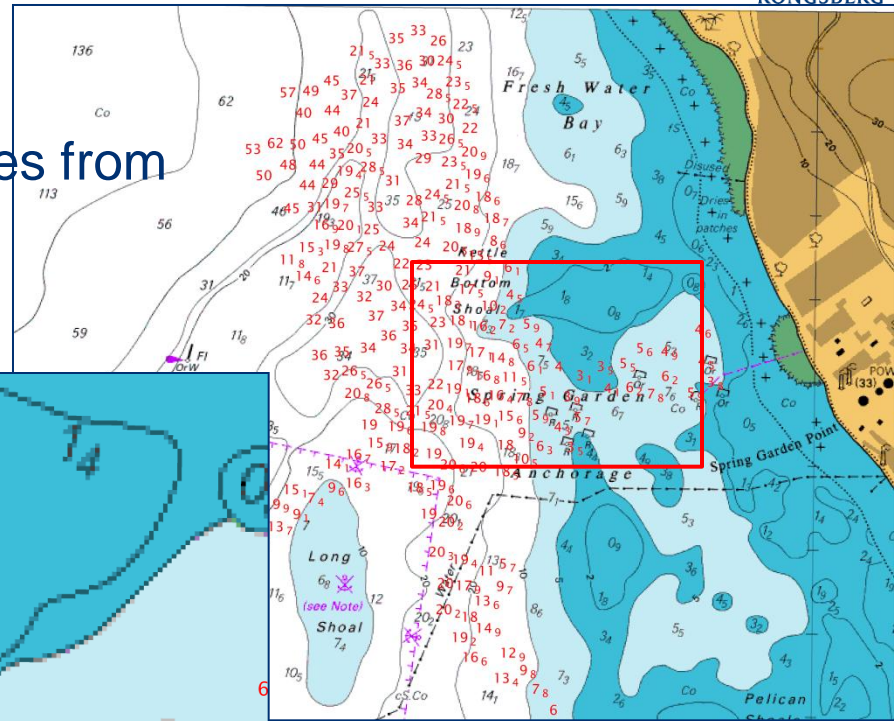

THE FULL PICTURE



# Recipe for Success



KONGSBERG

- Good Idea
- Financial and Resource Support
- Substantive Content
- Attendance Support
- Organizational Support
- Industry Support
- Host Commitment

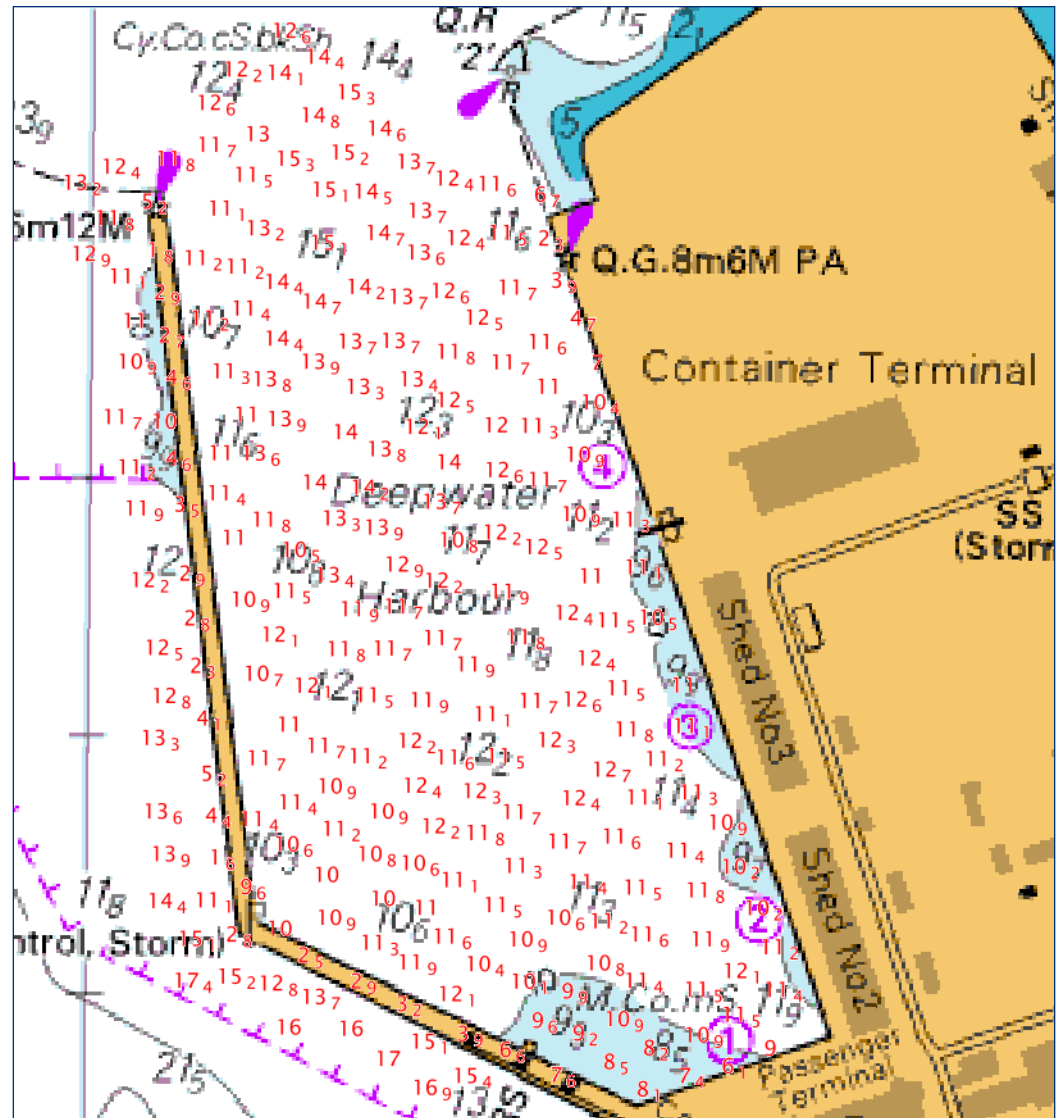

THE FULL PICTURE

# Sponsoring and Supporting Organizations

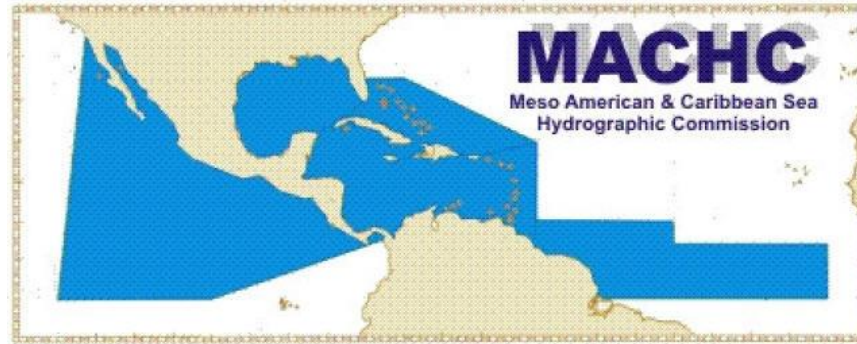

<http://www.iho-machc.org/>

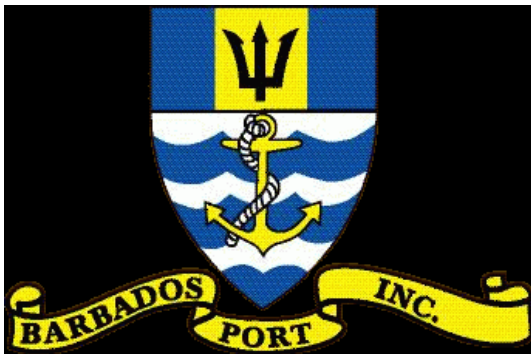

Port of Bridgetown

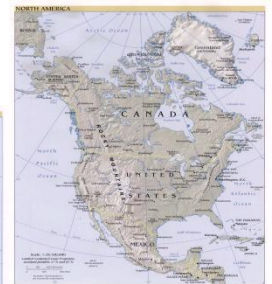
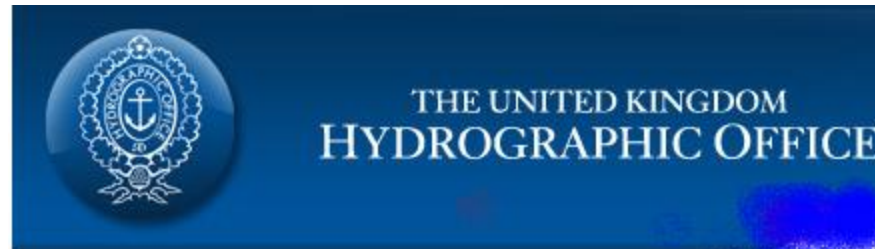

FULL PICTURE

# Hydrography Type I Project training class in St. John's, Antigua and Barbuda 30 May through 10 June 2011



KONGSBERG





**The IHO Capacity Building Sub Committee (CBSC) and Meso American Caribbean Sea Hydrographic Commission (MACHC) executed a planned Hydrography Type I Project training class in St. John's, Antigua and Barbuda 30 May through 10 June 2011.**

**The purpose of the Project was to establish hydrographic capacity in the region so that maritime authorities can begin providing necessary products and services to comply with basic requirements for safety of navigation in the area. Attendees to the training class included Barbados, British Virgin Islands, Dominica, El Salvador, Grenada, St Kitts and Nevis, St Lucia, St Vincent and Grenadines, and the host nation Antigua and Barbuda.**

**The basic course curriculum was developed by the UKHO. Industry participants CARIS, Kongsberg Maritime and Fugro contributed to the successful conduct of the training.**



KONGSBERG

**Portable, fully integrated EM 3002 MBES survey, system for shallow waters (300 kHz).**

**Consisting of**

- **MBES (EM 3002 S)**
- **Interated dGPS, heading and motion sensor (Seapath 200) (RTK GPS with reference station onshore)**
- **SVP sensors (AML)**
- **Mounting arrangement (from KM).**

**Installation and STW 2 to 3 days.**

**Demob 1 day.**





KONGSBERG

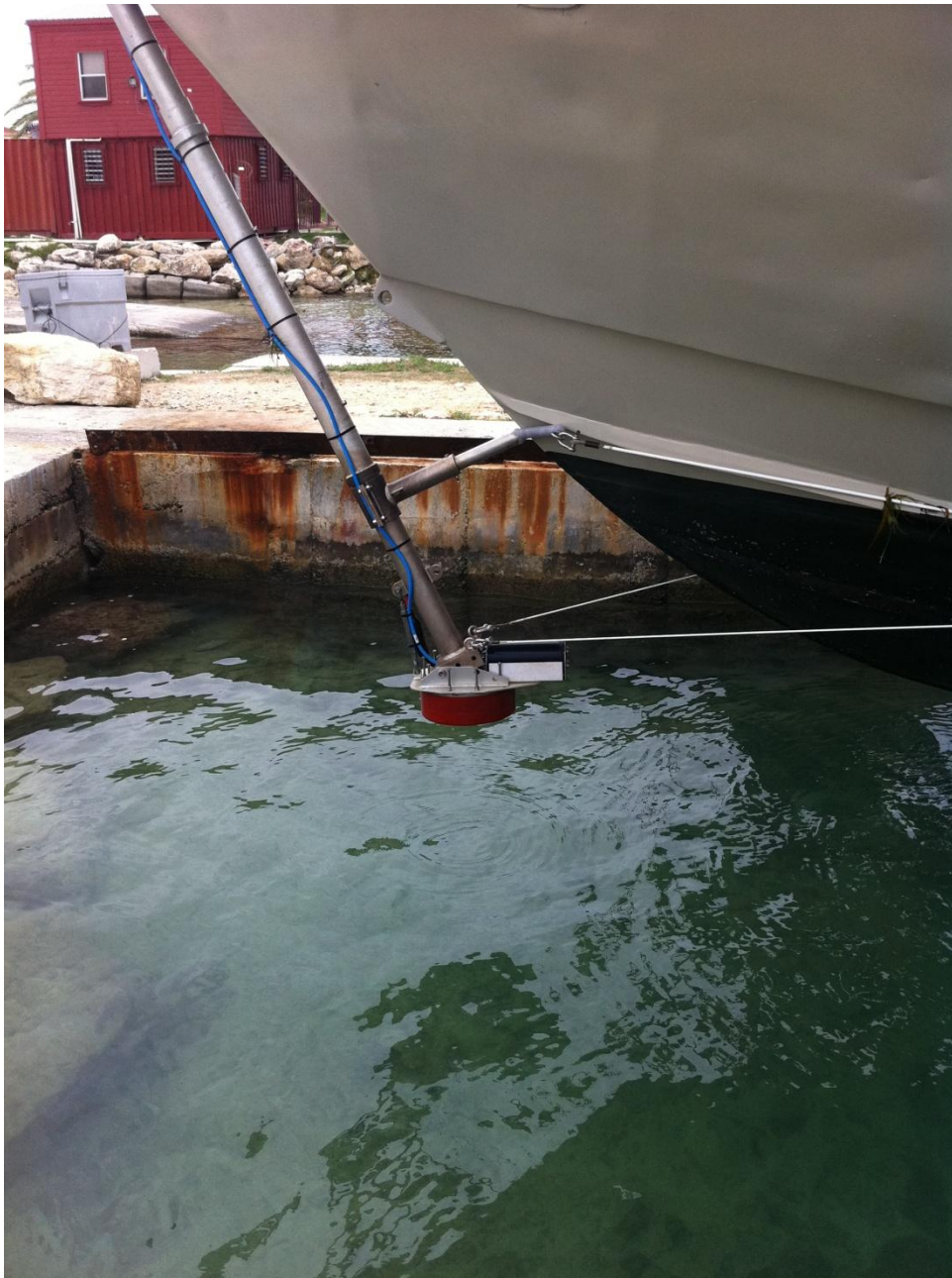

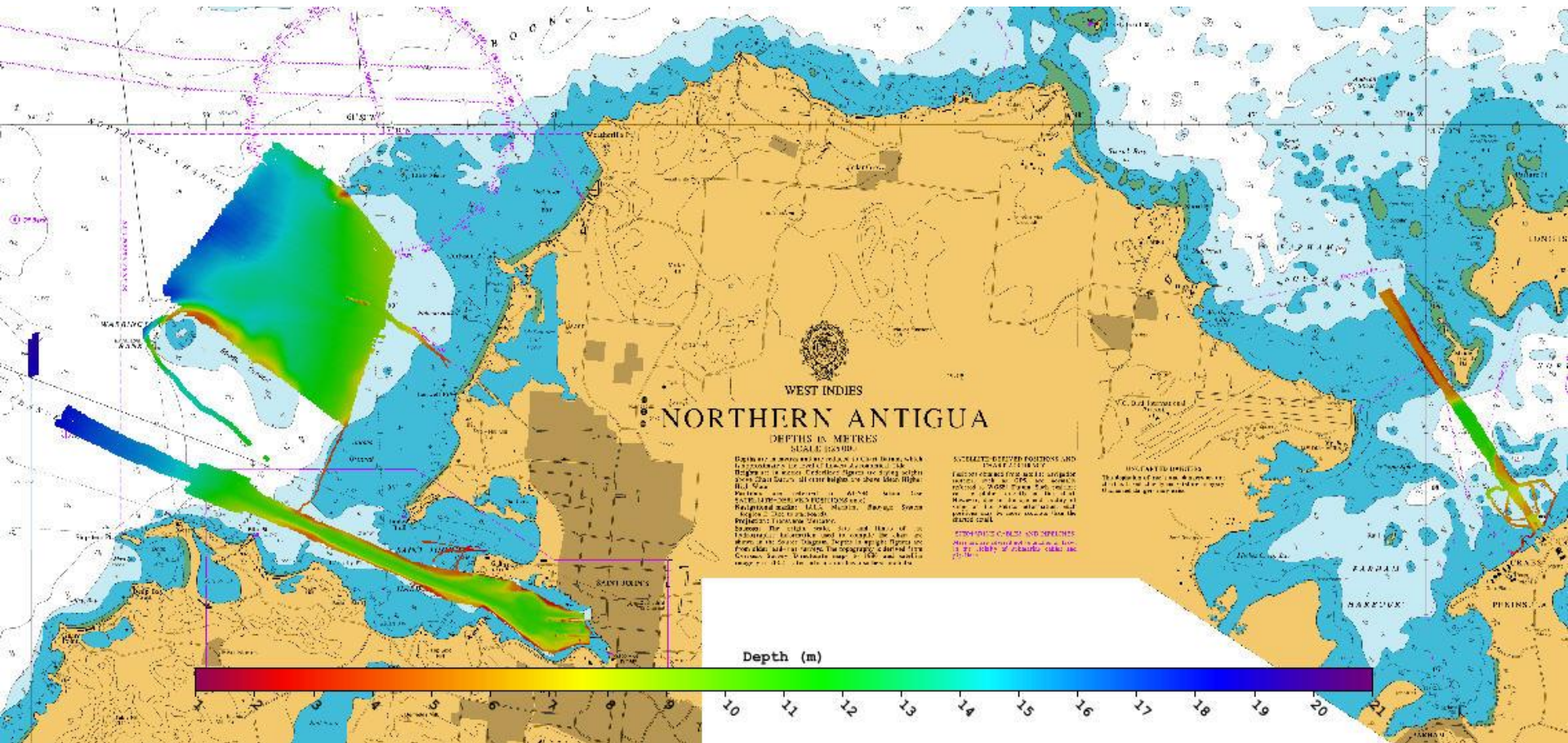

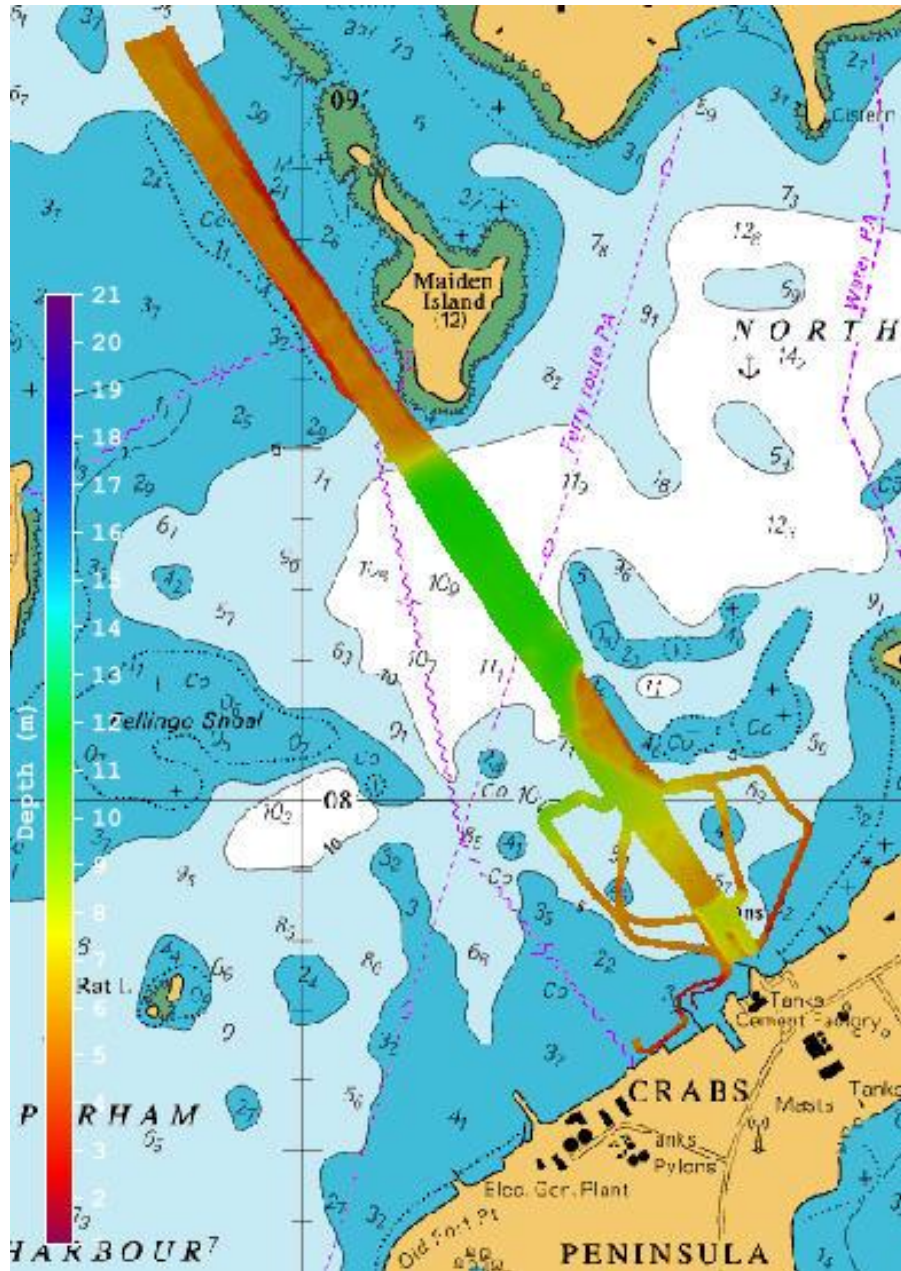



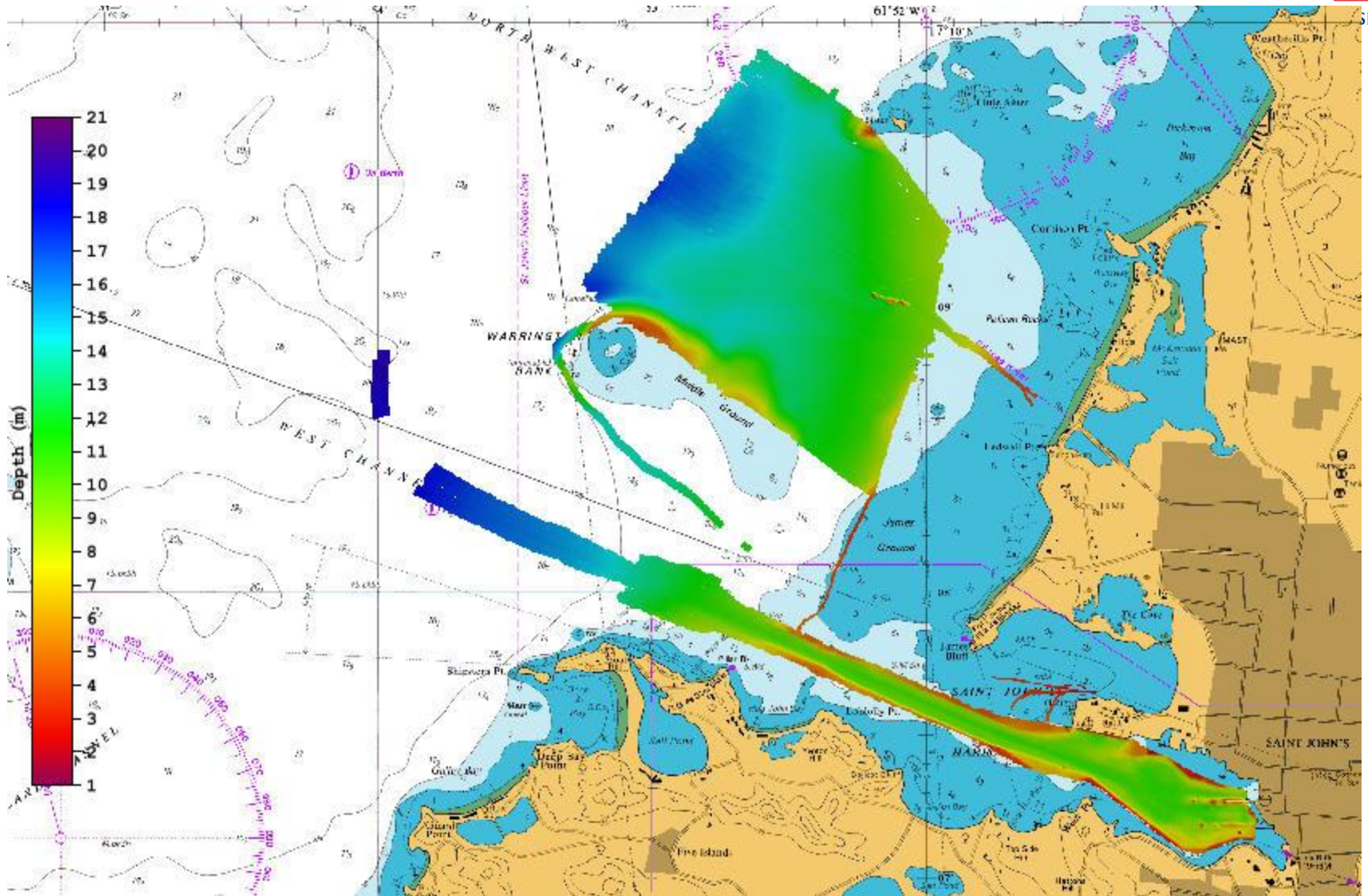

# IHO Workshop in HAITI September 4th to September 10th 2011



KONGSBERG





L' ORGANISATION HYDROGRAPHIQUE INTERNATIONALE (OHI)  
et  
L' INSTITUT PAN AMÉRICAIN DE GEOGRAPHIE ET D'HISTOIRE



Présenté par : *Jean-Louis Silencieux*

De Service Maritime et de Navigation d'Haïti

a suivi avec succès le stage de formation de Catégorie C OHI intitulé "LEVE HYDROGRAPHIQUE ET INTRODUCTION A LA PRODUCTION DE CARTES MARINES", organisé conjointement par le Bureau Hydrographique International (BHI) et l'Institut Pan Américain de Géographie et d'Histoire (PAIGH), à Port au Prince, Haïti, du 05 au 16 septembre 2011.

Date :

Paul COOPER  
PAIGH Hydrographic Coordinator

Captain Hugo GORZIGLIA  
IHB Director



## Product range - 2011

### **EM 2040 True wide band and high resolution Multibeam echosounder**

Applications from very high resolution inspection to shallow water surveys

#### **Key features:**

- 200 – 400 kHz operating frequency
- Max range >500m
- Single and dual RX
- Max coverage >500m, 140dg(S)/200dg(D)
- Dual swath with 800 soundings
- Sector transmitting, 3 sectors
- Modular design 0.5x1 and 1x1 (300kHz)
- Pingrate >50Hz
- Pulse length from <20ms to 600us using FM chirp and CW
- Roll, pitch compensated
- Roll, pitch, yaw stabilized
- Transducer depth rating 6000m



# Product range - 2011



KONGSBERG

## EM 2040 True wide band and high resolution Multibeam echosounder

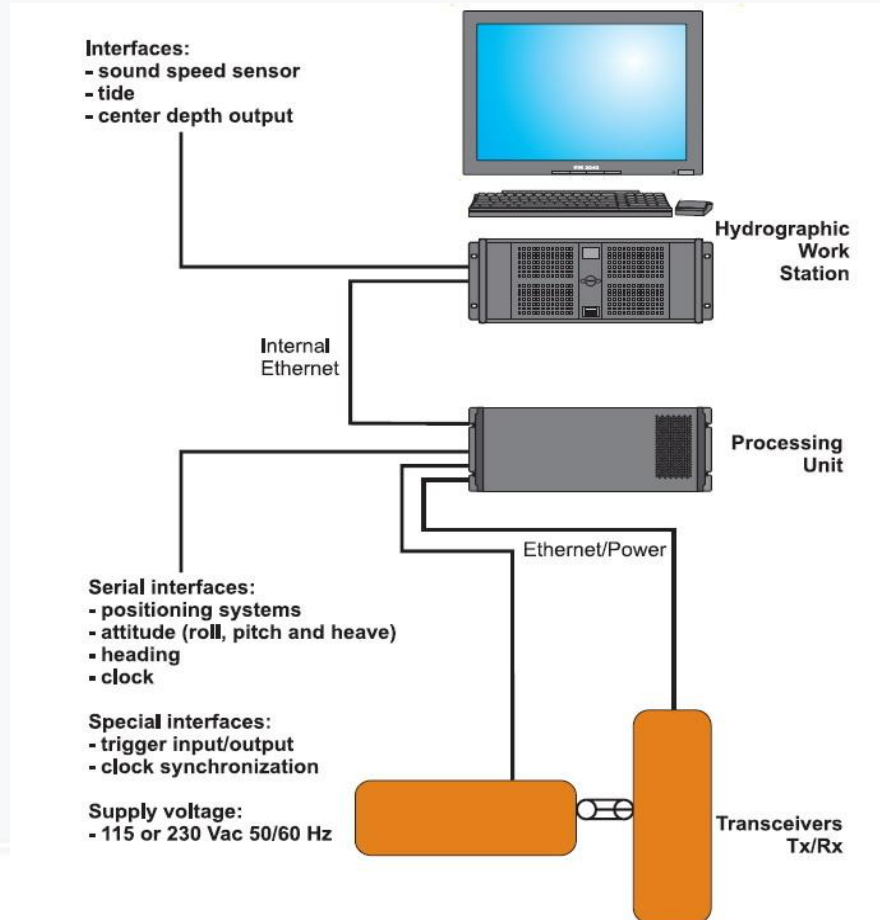

THE FULL PICTURE

# Product range - 2011



KONGSBERG

## EM 2040 True wide band and high resolution Multibeam echosounder

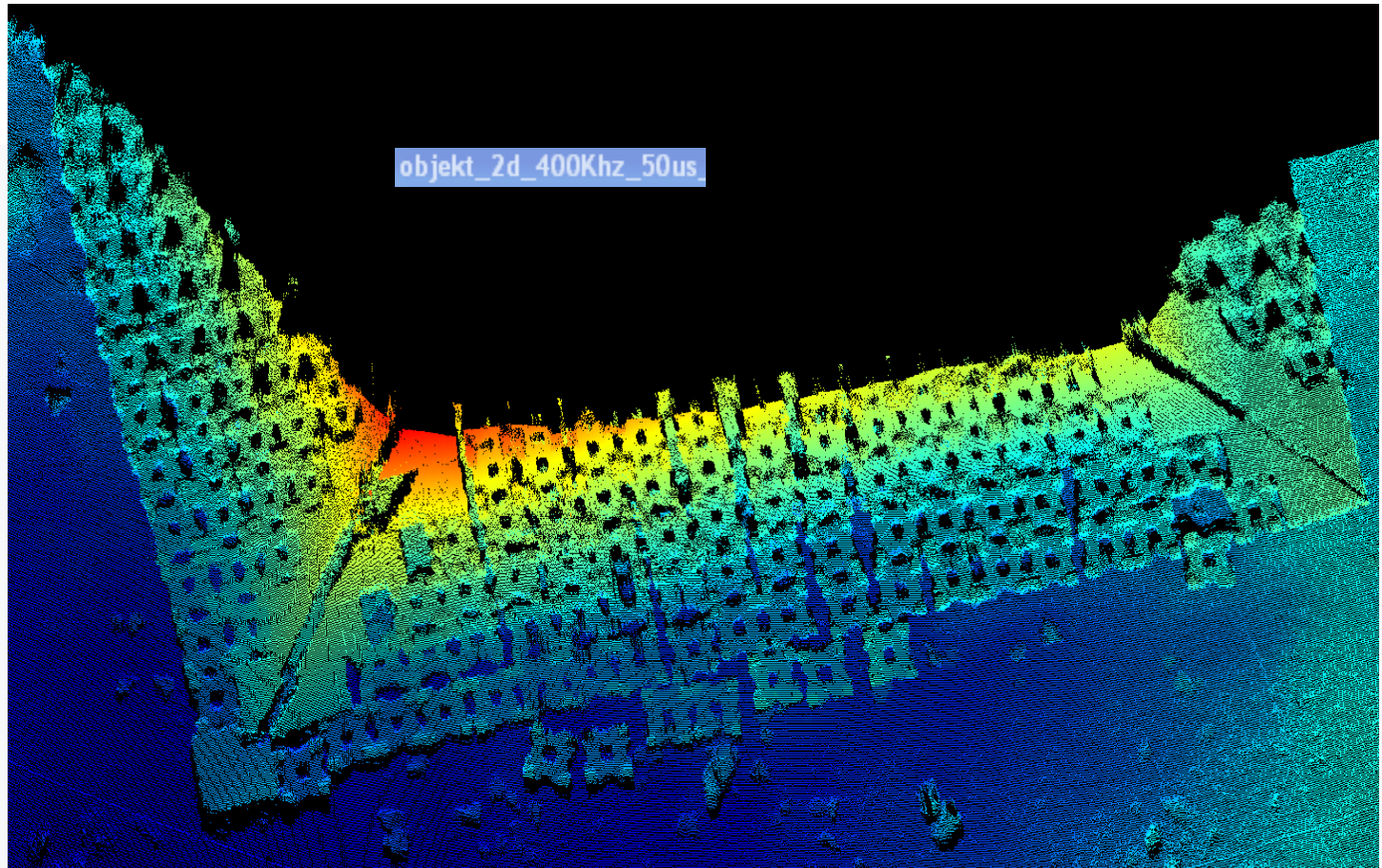

THE FULL PICTURE

# Product range - 2011



KONGSBERG

## **EM 2040 True wide band and high resolution Multibeam echosounder**

Passing over a forced  
hydrocarbon leakage

Mode: 400 kHz

Water depth: 20 m

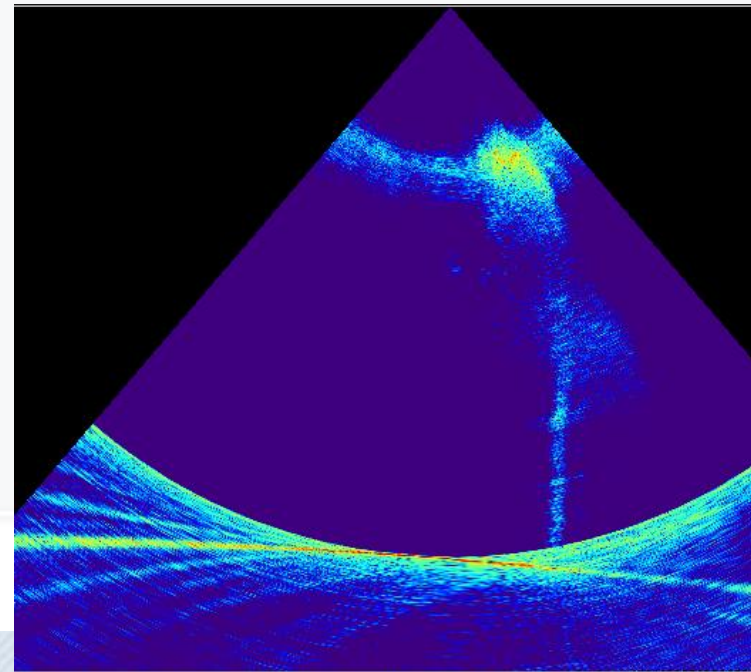
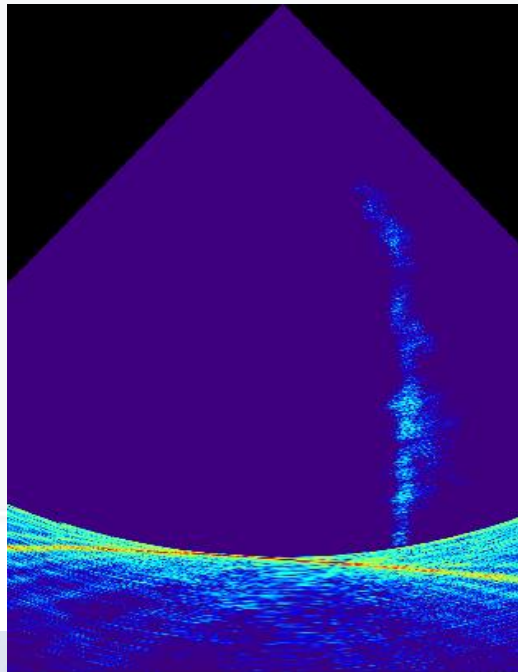

PICTURE

# Product range - 2011



KONGSBERG

## EM 2040 True wide band and high resolution Multibeam echosounder

Victor Hensen  
installation:  
EM 2040  
0.5 \* 1 degree  
Dual swath

Concrete target 2\*8 m  
One half is 50 cm higher  
A 1 m "tower" at the  
corner,  
30\*30 cm at top.  
19 m depth

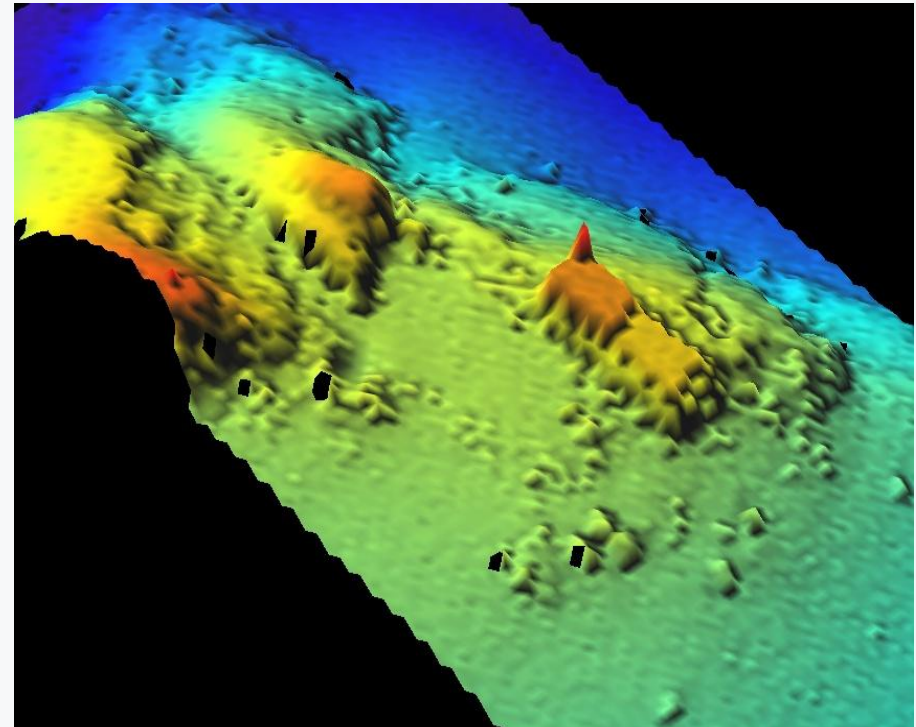
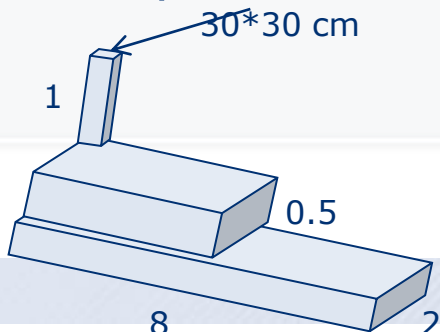

400 kHz, 50 us, one  
single line, gridded.

@Fugro OSAE, Victor  
Hensen

THE FULL PICTURE



# Product range - 2011



KONGSBERG

## EM 2040 True wide band and high resolution Multibeam echosounder

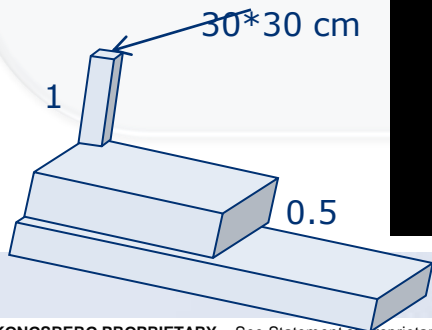
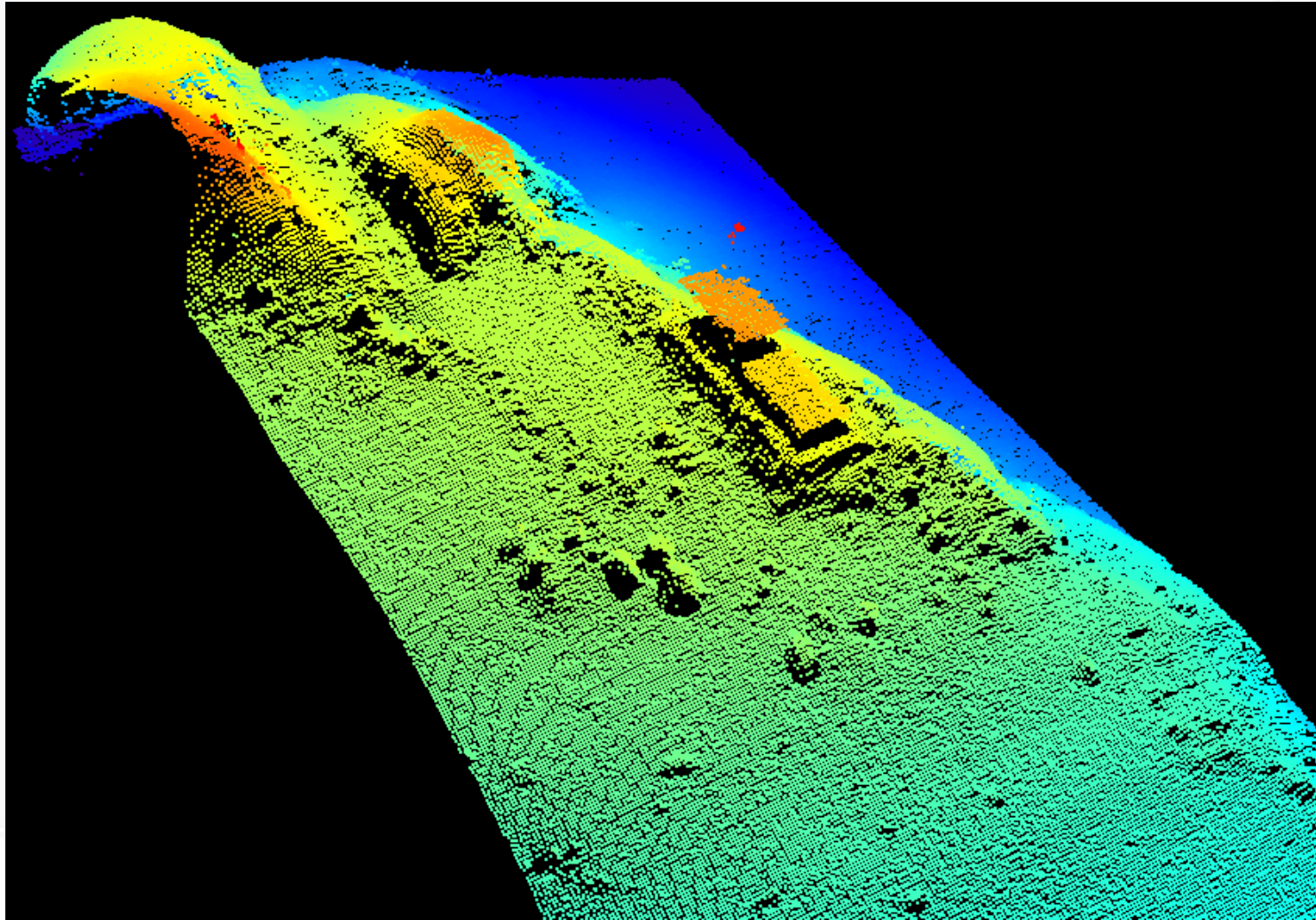

Same line, 3D, allpoints. Std = 2 cm on target surface

THE FULL PICTURE

# Product range - 2011



KONGSBERG

## EM 2040 True wide band and high resolution Multibeam echosounder

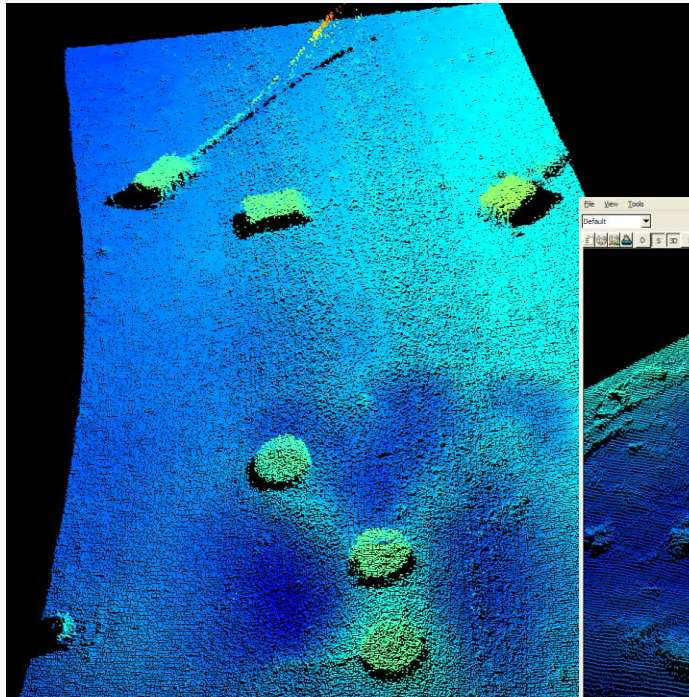

Marina  
moorings  
(1m diameter),  
allpoints

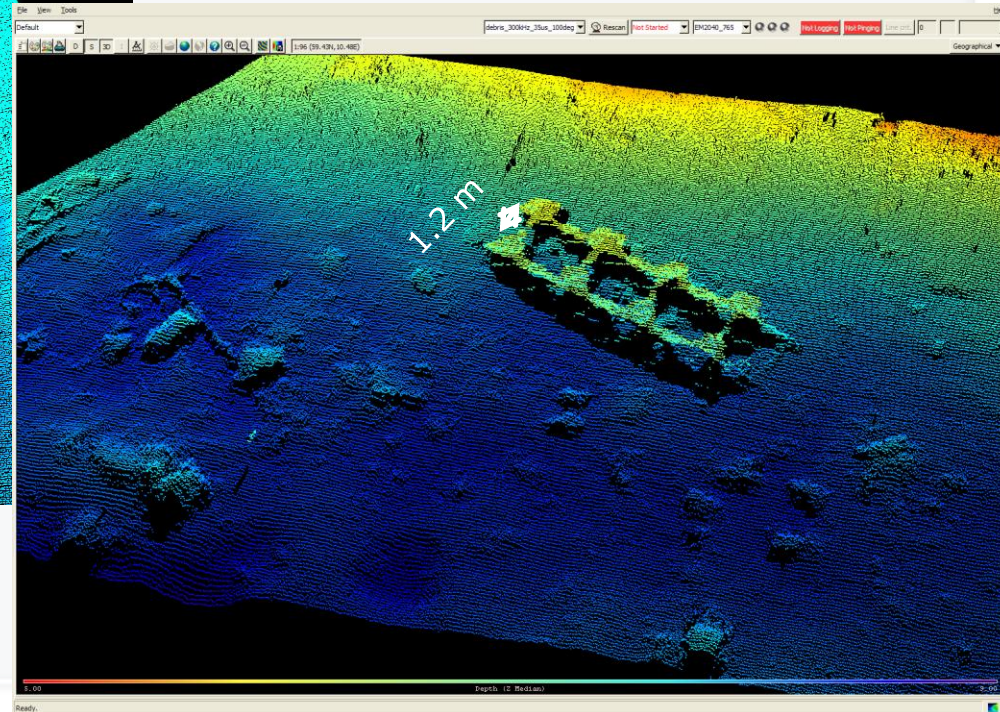

Debris, allpoints, 3D

THE FULL PICTURE

# Questions?



KONGSBERG





KONGSBERG

Thank You for Your Attention!

Kongsberg Maritime

